

Certificate of Test

March 2017

KAGA ELECTRONICS (USA) INC

Product Name : AC Adapter
Model Number : 1)KTPSxx-yyyyyDT-2P- VI (for Desktop Equipment)
2)KTPSxx-yyyyyzz-VI (for Direct Plug-In Equipment)
(xx can be 18 or 24 for output watt; yyyy can be 05040, 06035, 06040, 07030, 07530, 09025, 12020, 15016 (When xx=24W) and 05030,06025, 06030, 07025, 07525, 09022, 10019, 11016, 12016, 15013, 16012, 18011, 24008.(When xx = 18W). zz can be WA/EU/UK/AU/CN/KR/MP ;WA is US plug, EU is EU plug, UK is UK plug, AU is AU plug. MP is for Snap-fit plug with AU, UK, CN, EU, KR or US plug)
Test Report Number : 1702052F-01
Date of Test : July 07, 2015 – August 03, 2015

This product was tested according to the standards as below at the laboratory of Global EMC Standard Tech. Corp..

Standards:

FCC CFR 47, Part 15 Subpart B / CISPR 22 3rd Edition: 1997, Class B
ANSI C63.4: 2014
Canadian ICES-003 issue 6 (2016)

<http://www.gestek.com.tw>



Sharon Chang, President

GLOBAL EMC STANDARD TECH. CORP.

No.3, Baodoucuokeng, Linkou Dist., New Taipei
City 244, Taiwan(R.O.C.)
TEL:886-2-2603-5321
FAX:886-2-2603-5325

Issue Date: March 23, 2017



DECLARATION OF CONFORMITY

Per FCC Part 2 Section 2. 1077(a)



hereby declares that the product

Product Name: AC Adapter

Model Number: 1)KTPSxx-yyyyyDT-2P- VI (for Desktop Equipment)

2)KTPSxx-yyyyyzz-VI (for Direct Plug-In Equipment)

(xx can be 18 or 24 for output watt; yyyyy can be 05040, 06035, 06040, 07030, 07530, 09025, 12020, 15016 (When xx=24W) and 05030,06025, 06030, 07025, 07525, 09022, 10019, 11016, 12016, 15013, 16012, 18011, 24008.(When xx = 18W). zz can be WA/EU/UK/AU/CN/KR/MP ;WA is US plug, EU is EU plug, UK is UK plug, AU is AU plug. MP is for Snap-fit plug with AU, UK, CN, EU, KR or US plug)

Conforms to the following specifications:

FCC CFR 47, Part 15 Subpart B, Section 15.107(a), Section 15.109(a),

Class B Digital Device

Supplementary Information:

This device complies with part 15 of the FCC Rules. Operation is subject to the following two conditions: (1) This device may not cause harmful interference, and (2) this device must accept any interference received, including interference that may cause undesired operation.

Representative Person's Name : _____

Address: _____

Telephone number: _____

Signature : _____

Date : _____



KAGA ELECTRONICS (USA) INC

EUT: AC Adapter

Model Number: 1)KTPSxx-yyyyyDT-2P- VI (for Desktop Equipment)

2)KTPSxx-yyyyyzz-VI (for Direct Plug-In Equipment)

(xx can be 18 or 24 for output watt; yyyy can be 05040, 06035, 06040, 07030, 07530, 09025, 12020, 15016 (When xx=24W) and 05030,06025, 06030, 07025, 07525, 09022, 10019, 11016, 12016, 15013, 16012, 18011, 24008.(When xx = 18W). zz can be WA/EU/UK/AU/CN/KR/MP ;WA is US plug, EU is EU plug, UK is UK plug, AU is AU plug. MP is for Snap-fit plug with AU, UK, CN, EU, KR or US plug)

Prepared for:

KAGA ELECTRONICS (USA) INC

780 Montague Expy, Suite 403, San Jose, CA 95131 USA

**Report By : Global EMC Standard Tech. Corp.
No.3, Baodoucuokeng, Linkou Dist.,
New Taipei City 244, Taiwan(R.O.C.)
Tel : 886-2-2603-5321
Fax : 886-2-2603-5325**



Test results given in this report only relate to the specimen(s) tested, measured.
This report is the property of Global EMC Standard Tech. Corp., and shall not be reproduced, other than in full, without the written consent of Global EMC Standard Tech. Corp..
The client should not use it to claim product endorsement by TAF or any government agencies.
All data in this report are traceable to national standard or international standard.

TABLE OF CONTENTS

DESCRIPTION	PAGE
1. CERTIFICATION	3
2. SUMMARY OF TEST RESULTS	4
2.1 UNCERTAINTY DESCRIPTION	4
3. GENERAL INFORMATION	5
3.1 PRODUCTION DESCRIPTION	5
3.2 TEST MODES & EUT COMPONENTS DESCRIPTION.....	6
3.3 CONFIGURATION OF THE TESTED SYSTEM	8
3.4 BLOCK DIAGRAM OF CONNECTIONS BETWEEN EUT AND SIMULATORS.....	8
3.5 LAB AMBIENT	9
3.6 TEST FACILITY AUTHORIZATION AND ACCREDITATION.....	9
4. CONDUCTED EMISSION MEASUREMENT	10
4.1 TEST EQUIPMENTS	10
4.2 TEST METHOD	10
4.3 BLOCK DIAGRAM OF TEST SETUP	10
4.4 CONDUCTED EMISSION LIMITS	11
4.5 TEST CONFIGURATION ON MEASUREMENT	11
4.6 CONDUCTED EMISSION MEASURED PROCEDURE AND DATA	11
4.7 OPERATING CONDITIONS OF THE EUT	11
4.8 CONDUCTED EMISSION MEASUREMENT RESULTS	12
5. RADIATED EMISSION MEASUREMENT.....	16
5.1 TEST EQUIPMENT	16
5.2 TEST METHOD	16
5.3 OPEN AREA TEST SITE SETUP DIAGRAM.....	16
5.4 RADIATED EMISSION LIMIT	17
5.5 TEST CONFIGURATION.....	17
5.6 OPERATING CONDITION OF EUT.....	17
5.7 RADIATED EMISSION DATA.....	18
5.8 RADIATED EMISSIONS MEASUREMENT RESULTS	19
6. PHOTOGRAPHS FOR TEST.....	23
6.1 TEST PHOTOGRAPHS FOR CONDUCTION	23
6.2 TEST PHOTOGRAPHS FOR RADIATED.....	24
7. PHOTOGRAPHS FOR PRODUCT	25
8. EMI/EMS REDUCTION METHOD DURING COMPLIANCE TESTING	39

1. CERTIFICATION

Applicant : KAGA ELECTRONICS (USA) INC
EUT Description : AC Adapter
Model Number : 1)KTPSxx-yyyyyDT-2P- VI (for Desktop Equipment)
2)KTPSxx-yyyyyzz-VI (for Direct Plug-In Equipment)
(xx can be 18 or 24 for output watt; yyyy can be 05040, 06035, 06040, 07030, 07530, 09025, 12020, 15016 (When xx=24W) and 05030,06025, 06030, 07025, 07525, 09022, 10019, 11016, 12016, 15013, 16012, 18011, 24008.(When xx = 18W). zz can be WA/EU/UK/AU/CN/KR/MP ;WA is US plug, EU is EU plug, UK is UK plug, AU is AU plug. MP is for Snap-fit plug with AU, UK, CN, EU, KR or US plug)
Brand Name : KAGA
Serial Number : N/A

MEASUREMENT PROCEDURES USED:

- CFR 47, Part 15** Radio Frequency Device Subpart B Unintentional Radiators Class B
- CISPR 22 3rd Edition:1997** Limits and methods of measurement of radio disturbance Characteristics of information technology equipment: 1997
- ANSI C63.4** Methods of Measurements of Radio-Noise Emissions from Low- Voltage Electrical and Electronic Equipment in the range of 9kHz To 40GHz: 2014
- Canadian ICES-003 issue 6 (2016)** Implementation and Interpretation off the Interference-Causing Equipment Standard for Information Technology Equipment (ITE)-Limits and methods of measurement, ICES-003 issue 6 (2016)

THE MEASUREMENT SHOWN IN THE ATTACHMENT WAS MADE IN ACCORDANCE WITH THE PROCEDURES INDICATED, AND THE MAXIMUM ENERGY EMITTED BY THE EQUIPMENT WAS FOUND TO BE WITHIN THE ABOVE LIMITS APPLICABLE.

Sample Received Data : June 26, 2015
Date of Test : July 07, 2015 – August 03, 2015
Issue Date : March 17, 2017

In order to ensure the quality and accuracy of this document, the contents have been thoroughly reviewed by the following qualified personnel from Global EMC Standard Tech. Corp. Lab.

Documented By :

Mandy Chen

Mandy Chen / Report Author

Tested By :

Eric Tsai

Eric Tsai / eng. Dept. Supervisor

Approved By :

Tony Tsai

Tony Tsai / Director

2. SUMMARY OF TEST RESULTS

The worst emission data was found as following

STANDARD	TEST ITEM	TEST RESULT	REMARKS
(1)FCC Part 15 (2)CISPR 22 3 rd Edition:1997 (3)Canadian ICES-003 issue 6 (2016) Class B	Conducted emission (Mode 47)	PASS	The worst emission frequency is 0.1706 MHz. And minimum passing margin is <u>-5.56</u> dB. The measurement uncertainty is 3.88 dB.
	Radiated emission (Mode 47)	PASS	The worst emission frequency is <u>55.8500</u> MHz at <u>Vertical</u> . And minimum passing margin is <u>-8.95</u> dB. Height of antenna is <u>100</u> cm. Angle of turntable is <u>113</u> °. The measurement uncertainty is 4.10 dB.

2.1 UNCERTAINTY DESCRIPTION

According to CISPR 16-4-2,
 The measure level is compliance with the limit if

$$L_m < L_{lim} \text{ and } L_m + U(L_m) < L_{lim} + U_{cispr} = L_{eff}$$

Where,

U_{cispr} = Uncertainty value specified in Table 1 of CISPR 16-4-2

Measurement	U_{cispr}
Conducted disturbance (mains port) (150 kHz – 30 MHz)	3.6 dB
Radiated disturbance (OATS or ATS) (30 MHz – 1000 MHz)	5.2 dB

L_m = Measure value

L_{lim} = Emission limit level

$U(L_m)$ = Uncertainty value of test laboratory

L_{eff} = Effective emission limit level

The above stated condition will be taking as a criterion for pass/fail determination.

3. GENERAL INFORMATION

3.1 PRODUCTION DESCRIPTION

Product Name : AC Adapter

Model Number : 1)KTPSxx-yyyyyDT-2P- VI (for Desktop Equipment)
2)KTPSxx-yyyyyzz-VI (for Direct Plug-In Equipment)
(xx can be 18 or 24 for output watt; yyyy can be 05040, 06035, 06040, 07030, 07530, 09025, 12020, 15016 (When xx=24W) and 05030,06025, 06030, 07025, 07525, 09022, 10019, 11016, 12016, 15013, 16012, 18011, 24008.(When xx = 18W). zz can be WA/EU/UK/AU/CN/KR/MP ;WA is US plug, EU is EU plug, UK is UK plug, AU is AU plug. MP is for Snap-fit plug with AU, UK, CN, EU, KR or US plug)

Serial Number : N/A

Brand Name : KAGA

Applicant : KAGA ELECTRONICS (USA) INC

Address : 780 Montague Expy, Suite 403, San Jose, CA 95131 USA

Manufacturer : Boayang Electronics Co., Ltd.

Address : Di Feng Gong Yu Qu 2 Hao Xiasha Liuwu Village, Shipai Town Dong Guan City P. R. China

Power Supply : KTPS18-yyyyyDT-2P- VI and KTPS18-yyyyyzz-VI Input :100-240Vac, 50-60Hz, 0.48A
KTPS24-yyyyyDT-2P- VI and KTPS24-yyyyyzz-VI Input :100-240Vac, 50-60Hz, 0.58A

3.2 TEST MODES & EUT COMPONENTS DESCRIPTION

EUT: AC Adapter, M/N: 1)KTPSxx-yyyyyDT-2P- VI (for Desktop Equipment)
2)KTPSxx-yyyyyzz-VI (for Direct Plug-In Equipment)
(xx can be 18 or 24 for output watt; yyyy can be 05040, 06035, 06040, 07030, 07530, 09025, 12020, 15016 (When xx=24W) and 05030,06025, 06030, 07025, 07525, 09022, 10019, 11016, 12016, 15013, 16012, 18011, 24008.(When xx = 18W). zz can be WA/EU/UK/AU/CN/KR/MP ;WA is US plug, EU is EU plug, UK is UK plug, AU is AU plug. MP is for Snap-fit plug with AU, UK, CN, EU, KR or US plug)

Test Mode	Mode 1- Full Load (Pre-Scan Mode)	Mode 2- Full Load (Pre-Scan Mode)	Mode 3- Full Load (Pre-Scan Mode)
Test Model Number	KTPS24-05040DT-2P-VI	KTPS24-06035DT-2P-VI	KTPS24-06040DT-2P-VI
Test Mode	Mode 4- Full Load (Pre-Scan Mode)	Mode 5- Full Load (Pre-Scan Mode)	Mode 6- Full Load (Pre-Scan Mode)
Test Model Number	KTPS24-07030DT-2P-VI	KTPS24-07530DT-2P-VI	KTPS24-09025DT-2P-VI
Test Mode	Mode 7- Full Load (Pre-Scan Mode)	Mode 8- Full Load (Pre-Scan Mode)	Mode 9- Full Load (Worst Case)
Test Model Number	KTPS24-12020DT-2P-VI	KTPS24-15016DT-2P-VI	KTPS24-24010DT-2P-VI
Test Mode	Mode 10- Full Load (Pre-Scan Mode)	Mode 11- Full Load (Pre-Scan Mode)	Mode 12- Full Load (Pre-Scan Mode)
Test Model Number	KTPS24-48005DT-2P-VI	KTPS18-05030DT-2P-VI	KTPS18-06025DT-2P-VI
Test Mode	Mode 13- Full Load (Pre-Scan Mode)	Mode 14- Full Load (Pre-Scan Mode)	Mode 15- Full Load (Pre-Scan Mode)
Test Model Number	KTPS18-06030DT-2P-VI	KTPS18-07025DT-2P-VI	KTPS18-07525DT-2P-VI
Test Mode	Mode 17- Full Load (Pre-Scan Mode)		Mode 18- Full Load (Pre-Scan Mode)
Test Model Number	KTPS18-09022DT-2P-VI		KTPS18-10019DT-2P-VI
Test Mode	Mode 19- Full Load (Pre-Scan Mode)	Mode 20- Full Load (Pre-Scan Mode)	Mode 21- Full Load (Pre-Scan Mode)
Test Model Number	KTPS18-11016DT-2P-VI	KTPS18-12016DT-2P-VI	KTPS18-15013DT-2P-VI
Test Mode	Mode 22- Full Load (Pre-Scan Mode)	Mode 23- Full Load (Pre-Scan Mode)	Mode 24- Full Load (Worst Case)
Test Model Number	KTPS18-16012DT-2P-VI	KTPS18-18011DT-2P-VI	KTPS18-24008DT-2P-VI
Test Mode	Mode 25- Full Load (Pre-Scan Mode)	Mode 26- Full Load (Pre-Scan Mode)	Mode 27- Full Load (Pre-Scan Mode)
Test Model Number	KTPS24-05040WA-VI	KTPS24-06035WA-VI	KTPS24-06040WA-VI
Test Mode	Mode 28- Full Load (Pre-Scan Mode)	Mode 29- Full Load (Pre-Scan Mode)	Mode 30- Full Load (Pre-Scan Mode)
Test Model Number	KTPS24-07030WA-VI	KTPS24-07530WA-VI	KTPS24-09025WA-VI
Test Mode	Mode 31- Full Load (Pre-Scan Mode)	Mode 32- Full Load (Pre-Scan Mode)	Mode 33- Full Load (Worst Case)
Test Model Number	KTPS24-12020WA-VI	KTPS24-15016WA-VI	KTPS24-24010WA-VI
Test Mode	Mode 34- Full Load (Pre-Scan Mode)	Mode 35- Full Load (Pre-Scan Mode)	Mode 36- Full Load (Worst Case)
Test Model Number	KTPS24-48005WA-VI	KTPS18-05030WA-VI	KTPS18-06025WA-VI
Test Mode	Mode 37- Full Load (Pre-Scan Mode)	Mode 38- Full Load (Pre-Scan Mode)	Mode 39- Full Load (Pre-Scan Mode)
Test Model Number	KTPS18-06030WA-VI	KTPS18-07025WA-VI	KTPS18-07525WA-VI
Test Mode	Mode 40- Full Load (Pre-Scan Mode)	Mode 41- Full Load (Pre-Scan Mode)	Mode 42- Full Load (Pre-Scan Mode)
Test Model Number	KTPS18-09022WA-VI	KTPS18-10019WA-VI	KTPS18-11016WA-VI
Test Mode	Mode 43- Full Load (Pre-Scan Mode)	Mode 44- Full Load (Pre-Scan Mode)	Mode 45- Full Load (Pre-Scan Mode)
Test Model Number	KTPS18-12016WA-VI	KTPS18-15013WA-VI	KTPS18-16012WA-VI
Test Mode	Mode 46- Full Load (Pre-Scan Mode)		Mode 47- Full Load (Worst Case)
Test Model Number	KTPS18-18011WA-VI		KTPS18-24008WA-VI

Note:

1. According to pre-scan data, we determine the data (Mode 33, 47) shown in this test report, which reflects the worst-case data for each operation mode..
2. The EUT has serial model numbers for the requirement of marketing.

The difference of model numbers are shown as below:

Model No	Input Rated	Output Rated	Transformer	PCB		
KTPS24-05040DT-2P-VI KTPS24-05040WA-VI	100-240Vac, 50-60Hz, 0.58A	5Vdc, 4.0A, 20W	T1	SR		
KTPS24-06035DT-2P-VI KTPS24-06035WA-VI		5.9Vdc, 3.5A, 20.65W		SR		
KTPS24-06040DT-2P-VI KTPS24-06040WA-VI		5.9Vdc, 4.0A, 23.6W		SR		
KTPS24-07030DT-2P-VI KTPS24-07030WA-VI		7.0Vdc, 3.0A, 21W	T2	SR		
KTPS24-07530DT-2P-VI KTPS24-07530WA-VI				7.5Vdc, 3.0A, 22.5W	SR	
KTPS24-09025DT-2P-VI KTPS24-09025WA-VI		100-240Vac, 50-60Hz, 0.48A	9.0Vdc, 2.5A, 22.50W	T8	SBD	
KTPS24-12020DT-2P-VI KTPS24-12020WA-VI			12Vdc, 2.0A, 24W	T3	SBD	
KTPS24-15016DT-2P-VI KTPS24-15016WA-VI			15Vdc, 1.6A, 24W	T4	SBD	
KTPS24-24010DT-2P-VI KTPS24-24010WA-VI			24Vdc, 1.0A, 24W	T5	SBD	
KTPS24-48005DT-2P-VI KTPS24-48005WA-VI			48Vdc, 0.5A, 24W	T6	SBD	
KTPS18-05030DT-2P-VI KTPS18-05030WA-VI			100-240Vac, 50-60Hz, 0.48A	5Vdc, 3.0A, 15W	T7	SBD
KTPS18-06025DT-2P-VI KTPS18-06025WA-VI				5.9Vdc, 2.5A, 14.75W		SBD
KTPS18-06030DT-2P-VI KTPS18-06030WA-VI				5.9Vdc, 3.0A, 17.7W		SBD
KTPS18-07025DT-2P-VI KTPS18-07025WA-VI	7.0Vdc, 2.5A, 17.5W			T8	SBD	
KTPS18-07525DT-2P-VI KTPS18-07525WA-VI	7.5Vdc, 2.5A, 18.75W				SBD	
KTPS18-09022DT-2P-VI KTPS18-09022WA-VI	9.0Vdc, 2.2A, 19.8W	SBD				
KTPS18-10019DT-2P-VI KTPS18-10019WA-VI	10Vdc, 1.9A, 19W	T3		SBD		
KTPS18-11016DT-2P-VI KTPS18-11016WA-VI				11Vdc, 1.6A, 17.60W	SBD	
KTPS18-12016DT-2P-VI KTPS18-12016WA-VI				12Vdc, 1.6A, 19.2W	SBD	

Model No	Input Rated	Output Rated	Transformer	PCB
KTPS18-15013DT-2P-VI KTPS18-15013WA-VI	100-240Vac, 50-60Hz, 0.48A	15Vdc, 1.3A, 19.5W	T4	SBD
KTPS18-16012DT-2P-VI KTPS18-16012WA-VI	100-240Vac, 50-60Hz, 0.48A	16Vdc, 1.2A, 19.2W		SBD
KTPS18-18011DT-2P-VI KTPS18-18011WA-VI	100-240Vac, 50-60Hz, 0.48A	18Vdc, 1.1A, 19.8W		SBD
KTPS18-24008DT-2P-VI KTPS18-24008WA-VI	100-240Vac, 50-60Hz, 0.48A	24Vdc, 0.8A, 19.2W	T5	SBD

3.3 CONFIGURATION OF THE TESTED SYSTEM

The FCC IDs/Types for all equipment, plus descriptions of all cables used in the tested system (including inserted cards, which have grants) are:

Item	Device	No.	Configuration
1	Load	-----	Full Load: 24Ω for mode 33 Full Load: 30Ω for mode 47
2	Meter	-----	0-5A

Note: All the peripherals above were selected specifically after confirming that there is no impact on test results.

3.4 BLOCK DIAGRAM OF CONNECTIONS BETWEEN EUT AND SIMULATORS

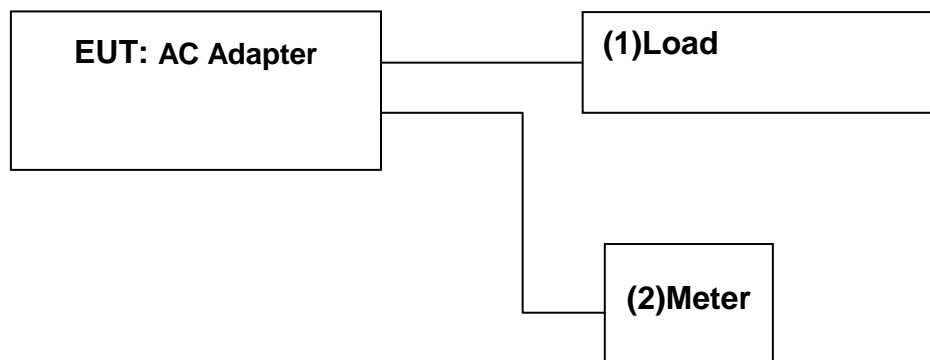

3.5 LAB AMBIENT

Items	Range Requirement
Temperature (°C)	10-40
Humidity (%RH)	10-90
Barometric pressure (mbar)	860-1060

3.6 TEST FACILITY AUTHORIZATION AND ACCREDITATION

Global EMC Standard Tech. Corp. is accredited in respect of laboratory and the accreditation criteria is ISO/IEC 17025: 2005.

AUTHORIZATION	
FCC SITE DESCRIPTION	Aug. 10, 1995 /Aug. 25, 1998 File on FCC Engineering Laboratory Federal Communications Commission Designation Number: TW1031, TW1032

ACCREDITATION	
Taiwan Accreditation Foundation (TAF)	Recognized by the Council of Taiwan Accreditation Foundation and confirmed to meet the requirements of ISO/IEC 17025. Registration No.: 1082 Registration on TAF effective through Sep. 18, 2015

4. CONDUCTED EMISSION MEASUREMENT

4.1 TEST EQUIPMENTS

Item	Instrument	Manufacturer	Model	S/N or Version	Next Cal. Date
1	TEST RECEIVER	RS	ESCS30	100393	2016.04.16
2	L.I.S.N.(EUT)	RS	ENV216	100108	2016.05.11
3	CABLE	GTK	N/A	GTK-E-A154-01	2016.01.09
4	Software	FARAD	EZ-EMC	2A1.1(USB)	N/A

Note: 1. All equipments are calibrated and will be valid only for a period of 1 year.

2. The test was performed at GTK Shielded Room B5.

4.2 TEST METHOD

According to CISPR 22 3rd Edition:1997

ANSI C63.4: 2014

4.3 BLOCK DIAGRAM OF TEST SETUP

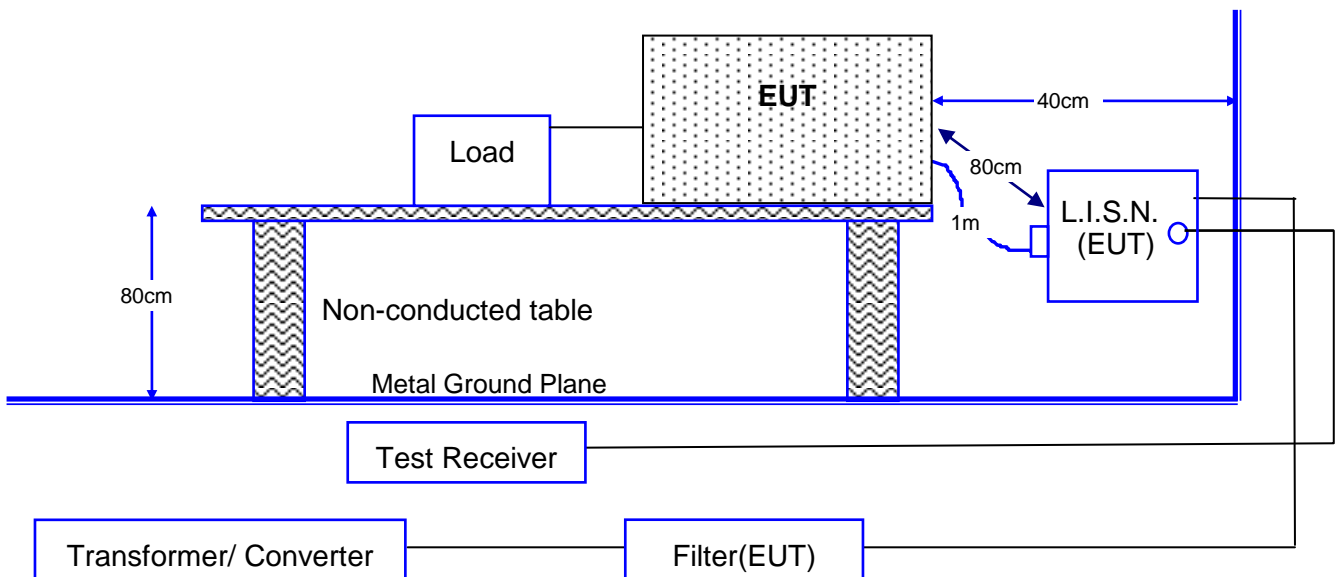

Note: This is a representative setup diagram for Table-top EUT.

For Floor-standing EUT, the table will be removed with all others setup condition remain the same.

4.4 CONDUCTED EMISSION LIMITS

Frequency	Voltage limits dB(μ V)	
	Class B	
MHz	QUASI-PEAK	AVERAGE
0.15 to 0.50	66 to 56	56 to 46
0.50 to 5.0	56	46
5.0 to 30	60	50

Remarks : In the Above Table, the tighter limit applies at the band edges.

4.5 TEST CONFIGURATION ON MEASUREMENT

The equipments that are listed in section 4.1 are installed on Conducted Power Line Test in order to meet the requirement of the Commission and operating in a manner, which tends to maximize its emission characteristics in a normal application.

The device under test, installed in a representative system as described in section 4.3, was placed on a non-conductive table whose total height equal to 80cm. Powered from one L.I.S.N. which signal output to receiver, and the other peripherals was powered from another L.I.S.N. which signal output was terminated by 50 Ω .

4.6 CONDUCTED EMISSION MEASURED PROCEDURE AND DATA

The measurement range of conducted emission, which is from 0.15 MHz to 30 MHz, was scan for peak emission curve of all the test modes. The worst mode is then measured using an average and/or quasi peak detector and record at least the disturbance levels and the frequencies of the six highest disturbances. The final measurement value is equal to the receiver reading plus the correction factor. If AMN insertion loss is more than 0.5dB, automatically the receiver will add the correction factor to the reading level.

4.7 OPERATING CONDITIONS OF THE EUT

The exercise program used during conducted emission measurement was designed to exercise the EUT in a manner similar to a typical use. The exercise sequence is listed as below:

1. Setup the EUT and simulators as shown on 4.3.
2. Turn on the power of all equipments.
3. Start test.

4.8 CONDUCTED EMISSION MEASUREMENT RESULTS

Date of Test	July 07, 2015	Temperature	26 °C
EUT	AC Adapter	Humidity	59 %
Test Mode	Mode 48	Display Pattern	N/A
Test Power Supply	AC 120V/60Hz		

Line

No.	Frequency MHz	Reading Level dB μ V	Factor dB	Measurement dB μ V	Limit dB μ V	Over Limit dB	Detector
1	0.1535	39.41	9.67	49.08	65.81	-16.73	QP
2	0.1535	16.75	9.67	26.42	55.81	-29.39	AVG
3	★0.1846	46.47	9.67	56.14	64.28	-8.14	QP
4	0.1846	28.74	9.67	38.41	54.28	-15.87	AVG
5	0.2521	39.79	9.66	49.45	61.69	-12.24	QP
6	0.2521	25.93	9.66	35.59	51.69	-16.10	AVG
7	0.3138	33.81	9.66	43.47	59.87	-16.40	QP
8	0.3138	19.81	9.66	29.47	49.87	-20.40	AVG
9	0.3805	31.10	9.65	40.75	58.27	-17.52	QP
10	0.3805	25.32	9.65	34.97	48.27	-13.30	AVG
11	13.5094	31.03	10.03	41.06	60.00	-18.94	QP
12	13.5094	24.88	10.03	34.91	50.00	-15.09	AVG

Remarks :

1. All readings are Quasi-peak and Average values.
2. Measurement = Reading + Factor (Could have ± 0.01 tolerance due to computer automatically round off calculation).
3. Over Limit (Margin Value)=Measurement level-Limit value.
4. Factor = L.I.S.N. insertion loss + cable loss
5. "★" means that this data is the worse case measurement level.
6. The measurement uncertainty is 3.88 dB.

Line

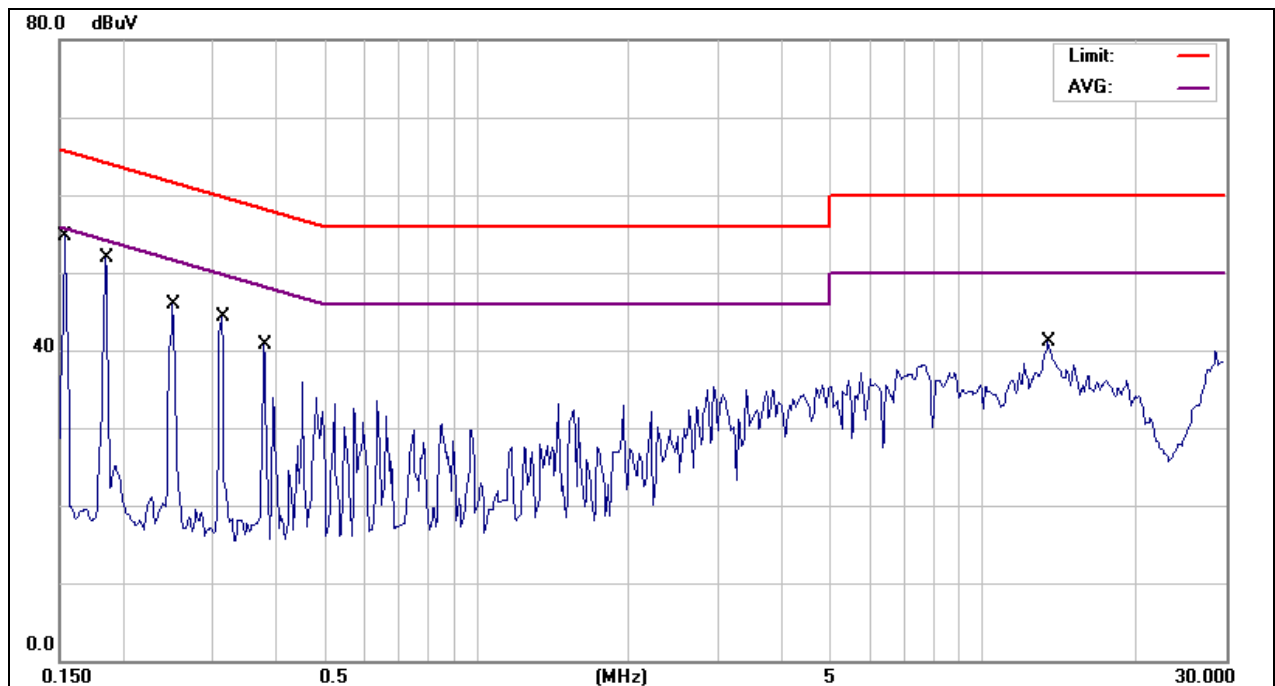

- Remark:
1. The Limit (The red line of the graph indicates the quasi-peak measurements).
 2. The AVG (The purple line of the graph indicates the average measurements).
 3. The scan curve indicates peak detector measurement.

Date of Test	July 07, 2015	Temperature	26 °C
EUT	AC Adapter	Humidity	59 %
Test Mode	Mode 48	Display Pattern	N/A
Test Power Supply	AC 120V/60Hz		

Neutral

No.	Frequency MHz	Reading Level dB μ V	Factor dB	Measurement dB μ V	Limit dB μ V	Over Limit dB	Detector
1	★0.1853	45.55	9.69	55.24	64.24	-9.00	QP
2	0.1853	28.65	9.69	38.34	54.24	-15.90	AVG
3	0.2592	39.86	9.69	49.55	61.46	-11.91	QP
4	0.2592	27.00	9.69	36.69	51.46	-14.77	AVG
5	0.3219	29.42	9.69	39.11	59.66	-20.55	QP
6	0.3219	23.91	9.69	33.60	49.66	-16.06	AVG
7	0.4234	28.42	9.68	38.10	57.38	-19.28	QP
8	0.4234	25.02	9.68	34.70	47.38	-12.68	AVG
9	2.6148	25.33	9.81	35.14	56.00	-20.86	QP
10	2.6148	22.10	9.81	31.91	46.00	-14.09	AVG
11	13.6070	30.83	10.13	40.96	60.00	-19.04	QP
12	13.6070	16.91	10.13	27.04	50.00	-22.96	AVG

Remarks :

1. All readings are Quasi-peak and Average values.
2. Measurement = Reading + Factor (Could have ± 0.01 tolerance due to computer automatically round off calculation).
3. Over Limit (Margin Value)=Measurement level-Limit value.
4. Factor = L.I.S.N. insertion loss + cable loss
5. "★" means that this data is the worse case measurement level.
6. The measurement uncertainty is 3.88 dB.

Neutral

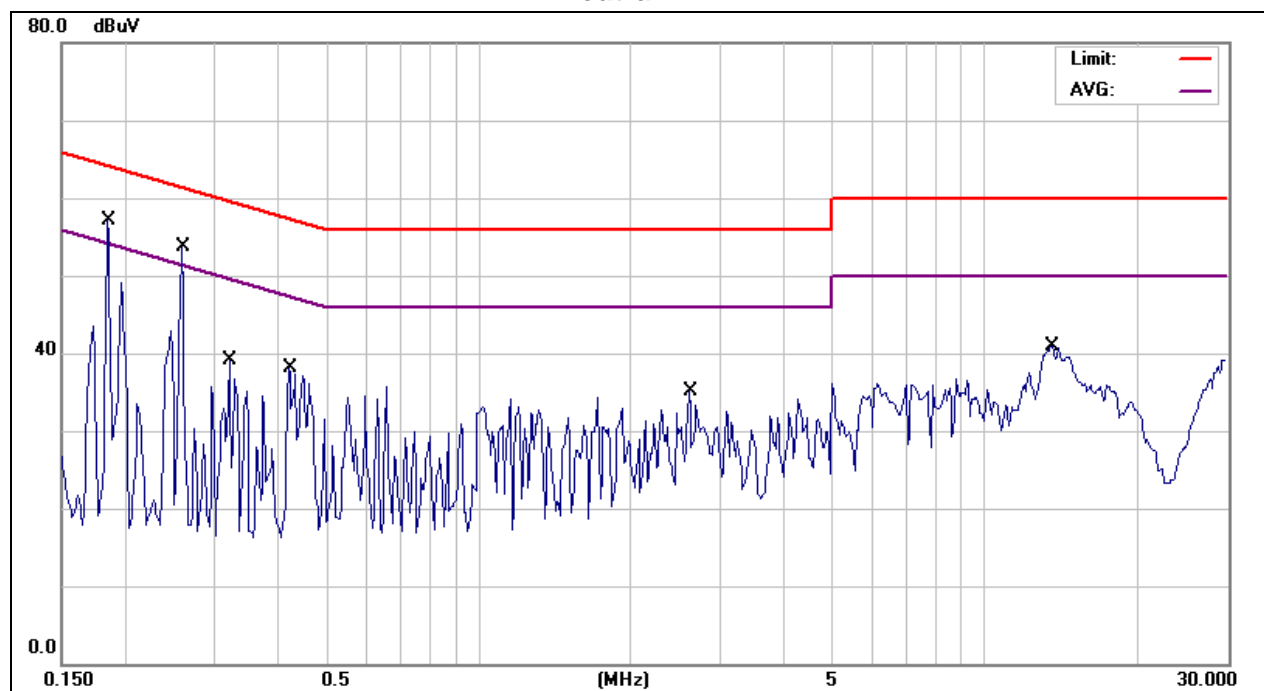

- Remark:
1. The Limit (The red line of the graph indicates the quasi-peak measurements).
 2. The AVG (The purple line of the graph indicates the average measurements).
 3. The scan curve indicates peak detector measurement.

Date of Test	July 15, 2015	Temperature	26 °C
EUT	AC Adapter	Humidity	59 %
Test Mode	Mode 33	Display Pattern	N/A
Test Power Supply	AC 120V/60Hz		

Line

No.	Frequency MHz	Reading Level dBµV	Factor dB	Measurement dBµV	Limit dBµV	Over Limit dB	Detector
1	★0.1706	49.70	9.67	59.37	64.93	-5.56	QP
2	0.1706	35.12	9.67	44.79	54.93	-10.14	AVG
3	0.2376	39.88	9.67	49.55	62.18	-12.63	QP
4	0.2376	24.66	9.67	34.33	52.18	-17.85	AVG
5	0.2421	39.92	9.67	49.59	62.02	-12.43	QP
6	0.2421	24.98	9.67	34.65	52.02	-17.37	AVG
7	0.2516	44.29	9.66	53.95	61.70	-7.75	QP
8	0.2516	35.63	9.66	45.29	51.70	-6.41	AVG
9	0.3141	38.53	9.66	48.19	59.86	-11.67	QP
10	0.3141	32.25	9.66	41.91	49.86	-7.95	AVG
11	0.4234	31.26	9.65	40.91	57.38	-16.47	QP
12	0.4234	25.14	9.65	34.79	47.38	-12.59	AVG

Remarks :

1. All readings are Quasi-peak and Average values.
2. Measurement = Reading + Factor (Could have ±0.01 tolerance due to computer automatically round off calculation).
3. Over Limit (Margin Value)=Measurement level-Limit value.
4. Factor = L.I.S.N. insertion loss + cable loss
5. " ★ " means that this data is the worse case measurement level.
6. The measurement uncertainty is 3.88 dB.

Line

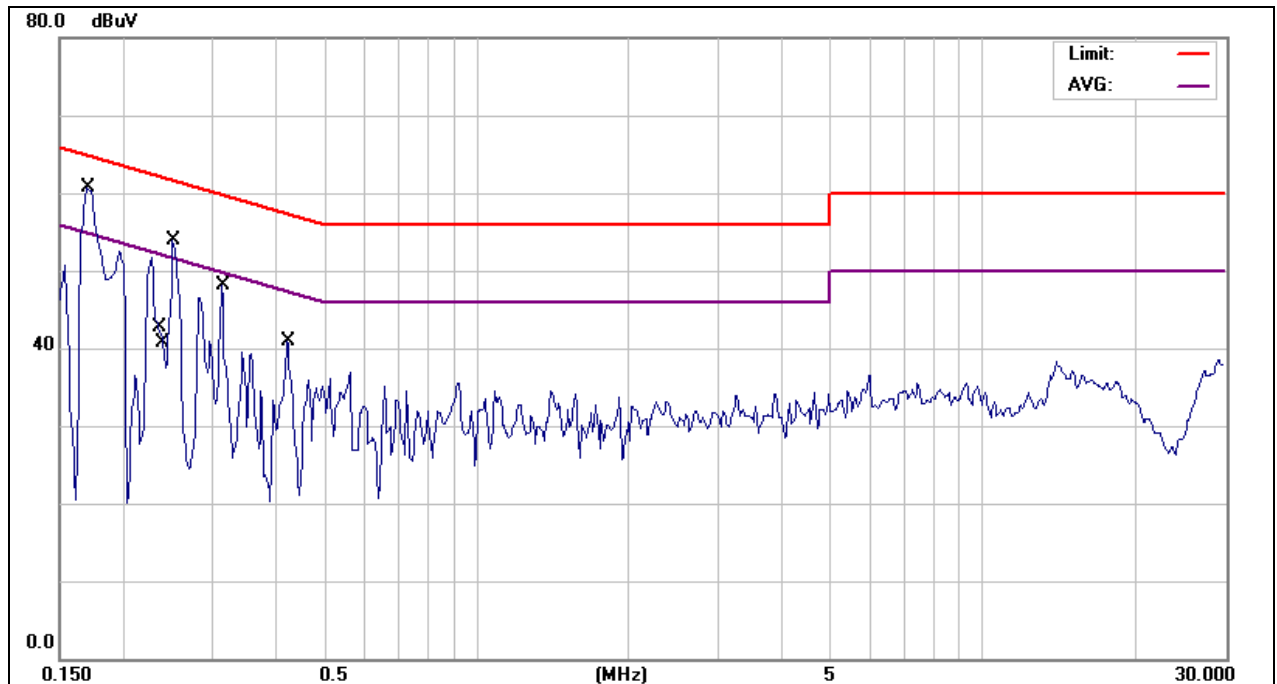

- Remark:
1. The Limit (The red line of the graph indicates the quasi-peak measurements).
 2. The AVG (The purple line of the graph indicates the average measurements).
 3. The scan curve indicates peak detector measurement.

Date of Test	July 15, 2015	Temperature	26 °C
EUT	AC Adapter	Humidity	59 %
Test Mode	Mode 33	Display Pattern	N/A
Test Power Supply	AC 120V/60Hz		

Neutral

No.	Frequency MHz	Reading Level dB μ V	Factor dB	Measurement dB μ V	Limit dB μ V	Over Limit dB	Detector
1	★0.1697	48.85	9.70	58.55	64.98	-6.43	QP
2	0.1697	34.38	9.70	44.08	54.98	-10.90	AVG
3	0.1939	37.81	9.69	47.50	63.87	-16.37	QP
4	0.1939	22.39	9.69	32.08	53.87	-21.79	AVG
5	0.2352	40.01	9.69	49.70	62.26	-12.56	QP
6	0.2352	26.21	9.69	35.90	52.26	-16.36	AVG
7	0.2984	33.71	9.69	43.40	60.29	-16.89	QP
8	0.2984	26.80	9.69	36.49	50.29	-13.80	AVG
9	0.4313	31.05	9.68	40.73	57.23	-16.50	QP
10	0.4313	25.71	9.68	35.39	47.23	-11.84	AVG
11	0.4781	29.00	9.68	38.68	56.37	-17.69	QP
12	0.4781	23.39	9.68	33.07	46.37	-13.30	AVG

Remarks :

1. All readings are Quasi-peak and Average values.
2. Measurement = Reading + Factor (Could have ± 0.01 tolerance due to computer automatically round off calculation).
3. Over Limit (Margin Value)=Measurement level-Limit value.
4. Factor = L.I.S.N. insertion loss + cable loss
5. "★" means that this data is the worse case measurement level.
6. The measurement uncertainty is 3.88 dB.

Neutral

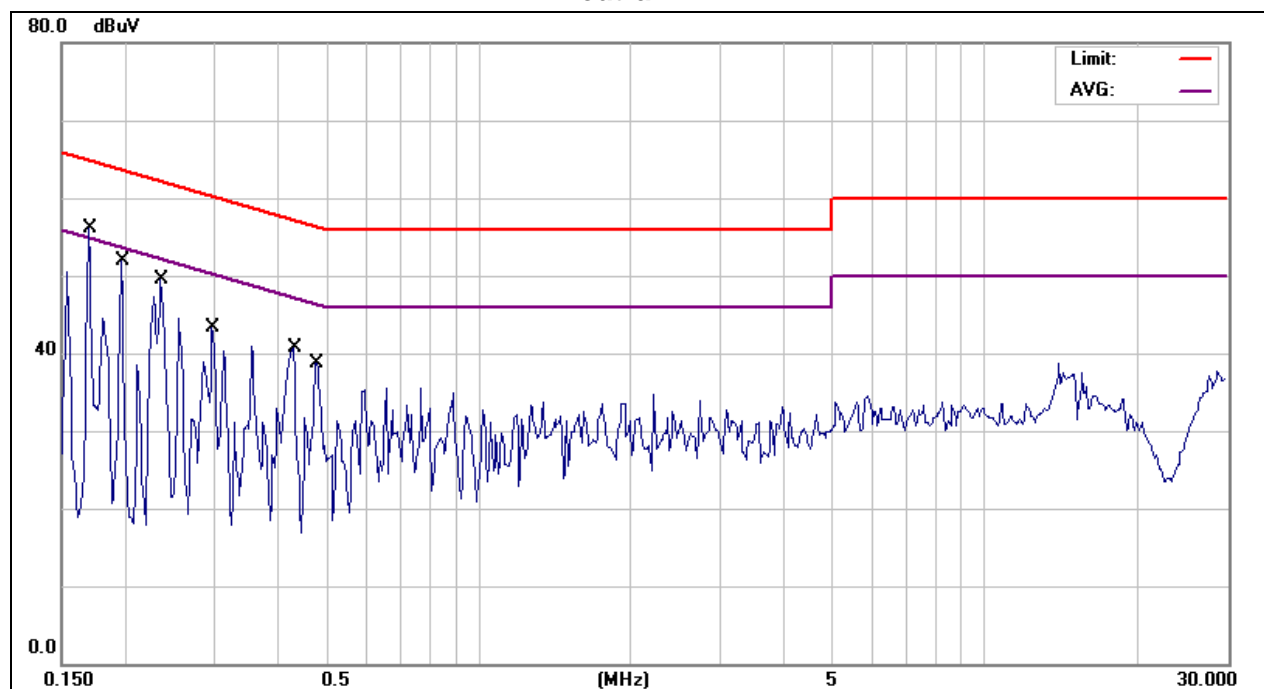

- Remark:
1. The Limit (The red line of the graph indicates the quasi-peak measurements).
 2. The AVG (The purple line of the graph indicates the average measurements).
 3. The scan curve indicates peak detector measurement.

5. RADIATED EMISSION MEASUREMENT

5.1 TEST EQUIPMENT

The following test equipments are used during the radiated emission tests:

Item	Instrument	Manufacturer	Model	S/N or Version	Next Cal. Date
1	TEST RECEIVER	RS	ESCS30	849650/023	2016.05.02
2	SPECTRUM	ADVANTEST	R3172	150800149	2016.02.05
3	PRE-AMPLIFIER	HP	8447D	2944A08273	2015.09.30
4	BILOG ANTENNA	SCHAFFNER	CBL6112B	2833	2016.06.30
5	CABLE	PEWC	CFD400-NL	GTK-E-A408-01	2016.02.25
6	Software	FARAD	EZ-EMC	2A1.1(USB)	N/A

Note: 1. All equipments are calibrated and will be valid only for a period of 1 year.

2. The test was performed at GTK Open Site B2.

5.2 TEST METHOD

According to CISPR 22 3rd Edition:1997

ANSI C63.4: 2014

5.3 OPEN AREA TEST SITE SETUP DIAGRAM

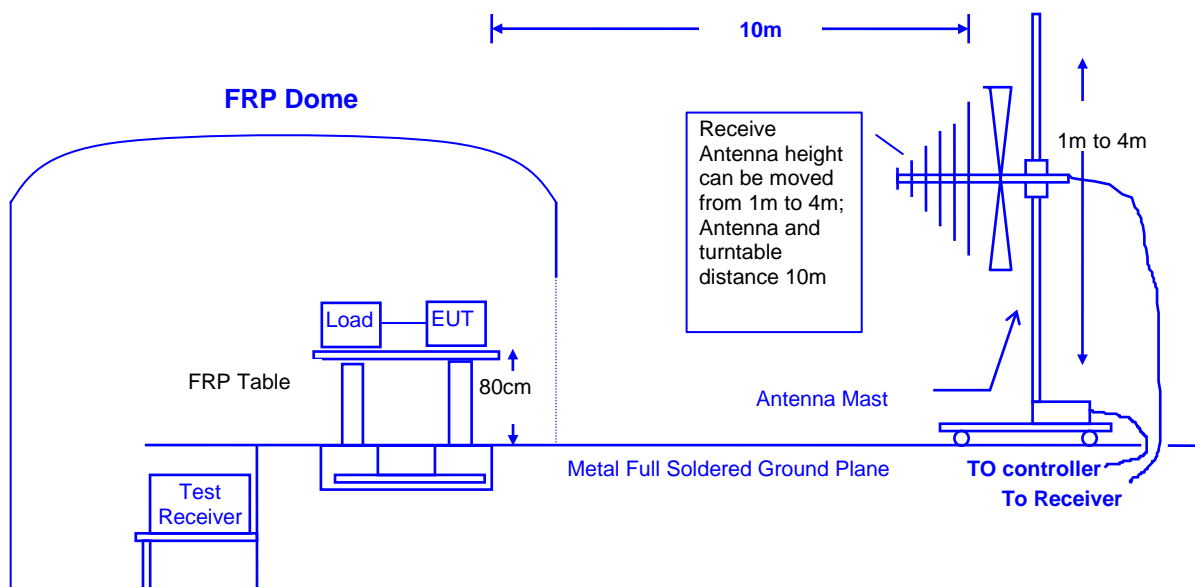

Note: This is a representative setup diagram for Table-top EUT.

For Floor-standing EUT, the table will be removed with all others setup condition remain the same.

5.4 RADIATED EMISSION LIMIT

Frequency	CISPR Class B	
	Distance	Field Strength
MHz	Meter	dB(μ V/m)
30 to 230	10	30
230 to 1000	10	37

Remark :1. The tighter limit shall apply at the edge between two frequency bands.

2. Distance refers to the distance in meters between the measuring instrument antenna and the closed point of any part of the device or system.

5.5 TEST CONFIGURATION

The equipments which are listed 5.1 are installed on Radiated Emission Test to meet the Commission requirement and operating in a manner which tends to maximize its emission characteristics in a normal application.

The device under test, installed in a representative system as described in section 5.3., was placed on a non-conductive table whose total height equaled 80 cm. This table can be rotated 360 degree. The measurement antenna was mounted to a non-conductive mast capable of moving the antenna vertically. Antenna height was varied from 1 meter to 4 meters and the system under test was rotated from 0 degree through 360 degrees relative to the antenna position and polarization (Horizontal and Vertical). Also the I/O cable position was investigated to find the maximum emission condition.

5.6 OPERATING CONDITION OF EUT

Same as section 4.7.

5.7 RADIATED EMISSION DATA

According 47CFR PART 15 subpart B section 15.33(b)(1), the lowest radio frequency signal generated or used in the device, without going below the lowest frequency for which a radiated emission limit is specified, up to the frequency shown in the following table:

Highest frequency generated or used in the device or on which the device operates or tunes (MHz)	Upper frequency of measurement rang (MHz)
Below 1.705	30
1.705-108	1000
108-500	2000
500-1000	5000
Above 1000	5 th harmonic of the highest frequency or 40 GHz, whichever is lower

Remark: The highest tested frequency is generated by the **150 kHz**.
At least, the upper frequency of measurement range is **1GHz**.

5.7.1 30 MHz to 1 GHz

The measurement range of radiated emission, which is from **30 MHz to 1 GHz**, was investigated. All readings are quasi-peak values with a resolution bandwidth of 120 kHz. The initial step in collecting radiated emission data is a spectrum analyzer peak scans of the measurement range for all the test modes and then use test receiver for final measurement and record at least the disturbance levels and the frequencies of the six highest disturbances. Then the worst modes were reported the following data pages.

5.8 RADIATED EMISSIONS MEASUREMENT RESULTS

Date of Test	August 03, 2015	Temperature	25 deg/C
EUT	AC Adapter	Humidity	60 %RH
Working Cond.	Mode 33	Display Pattern	N/A
Antenna distance	10m at Horizontal	Test Frequency Range	30-1000MHz
Test Power Supply	AC 120V/60Hz		

No.	Frequency MHz	Reading Level dBμV	Factor dB	Measurement dBμV/m	Limit dBμV/m	Over Limit dB	Detector
1	★56.9600	36.63	-19.30	17.33	30.00	-12.67	QP
2	75.0000	35.12	-18.82	16.30	30.00	-13.70	QP
3	118.3200	30.20	-13.37	16.83	30.00	-13.17	QP
4	160.3000	28.52	-14.48	14.04	30.00	-15.96	QP
5	191.3200	29.63	-14.86	14.77	30.00	-15.23	QP
6	209.3600	30.10	-13.97	16.13	30.00	-13.87	QP

Remarks:

1. All Readings below 1GHz are Quasi-Peak.
2. Measurement = Reading + Factor (Could have ±0.01 tolerance due to computer automatically round off calculation).
3. Over Limit (Margin Value)=Measurement level-Limit value.
4. Factor = antenna factor + cable loss – amplifier gain.
5. “★” means that this data is the worst case measurement level.
6. The antenna height could have ±1cm tolerance and the turn table degree could have ±1° tolerance.
7. The measurement uncertainty is 4.10 dB.

80.0 dBμV/m

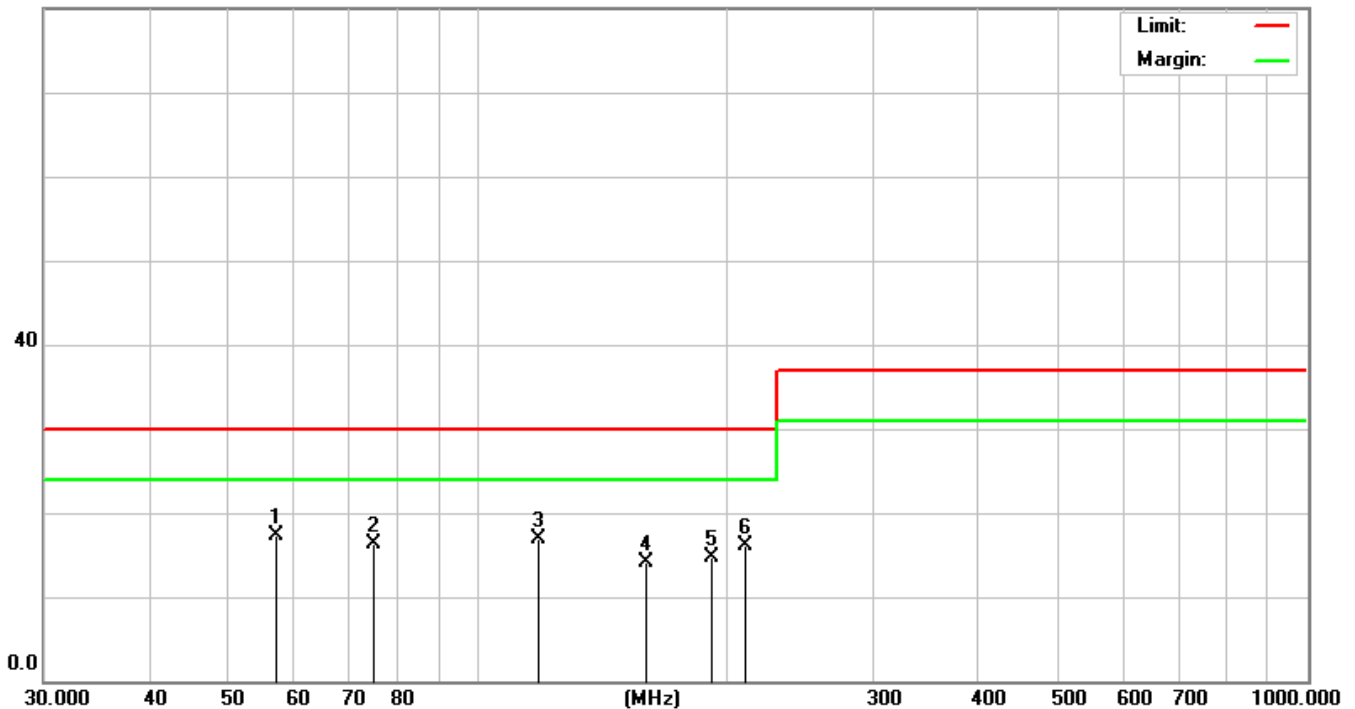

- Remark:
1. The Limit (The red line of the graph indicates the quasi -peak measurements).
 2. The Margin (The green line of the graph indicates the 6dB margin).

Date of Test	August 03, 2015	Temperature	25 deg/C
EUT	AC Adapter	Humidity	60 %RH
Working Cond.	Mode 33	Display Pattern	N/A
Antenna distance	10m at Vertical	Test Frequency Range	30-1000MHz
Test Power Supply	AC 120V/60Hz		

No.	Frequency MHz	Reading Level dBμV	Factor dB	Measurement dBμV/m	Limit dBμV/m	Over Limit dB	Detector
1	56.2000	39.60	-19.22	20.38	30.00	-9.62	QP
2	72.2000	38.00	-19.00	19.00	30.00	-11.00	QP
3	118.6000	32.59	-13.36	19.23	30.00	-10.77	QP
4	150.6000	33.36	-14.09	19.27	30.00	-10.73	QP
5	★190.6000	35.80	-14.88	20.92	30.00	-9.08	QP
6	208.0000	34.23	-14.07	20.16	30.00	-9.84	QP

Remarks:

1. All Readings below 1GHz are Quasi-Peak.
2. Measurement = Reading + Factor (Could have ±0.01 tolerance due to computer automatically round off calculation).
3. Over Limit (Margin Value)=Measurement level-Limit value.
4. Factor = antenna factor + cable loss – amplifier gain.
5. “★” means that this data is the worst case measurement level.
6. The antenna height could have ±1cm tolerance and the turn table degree could have ±1° tolerance.
7. The measurement uncertainty is 4.10 dB.

80.0 dBuV/m

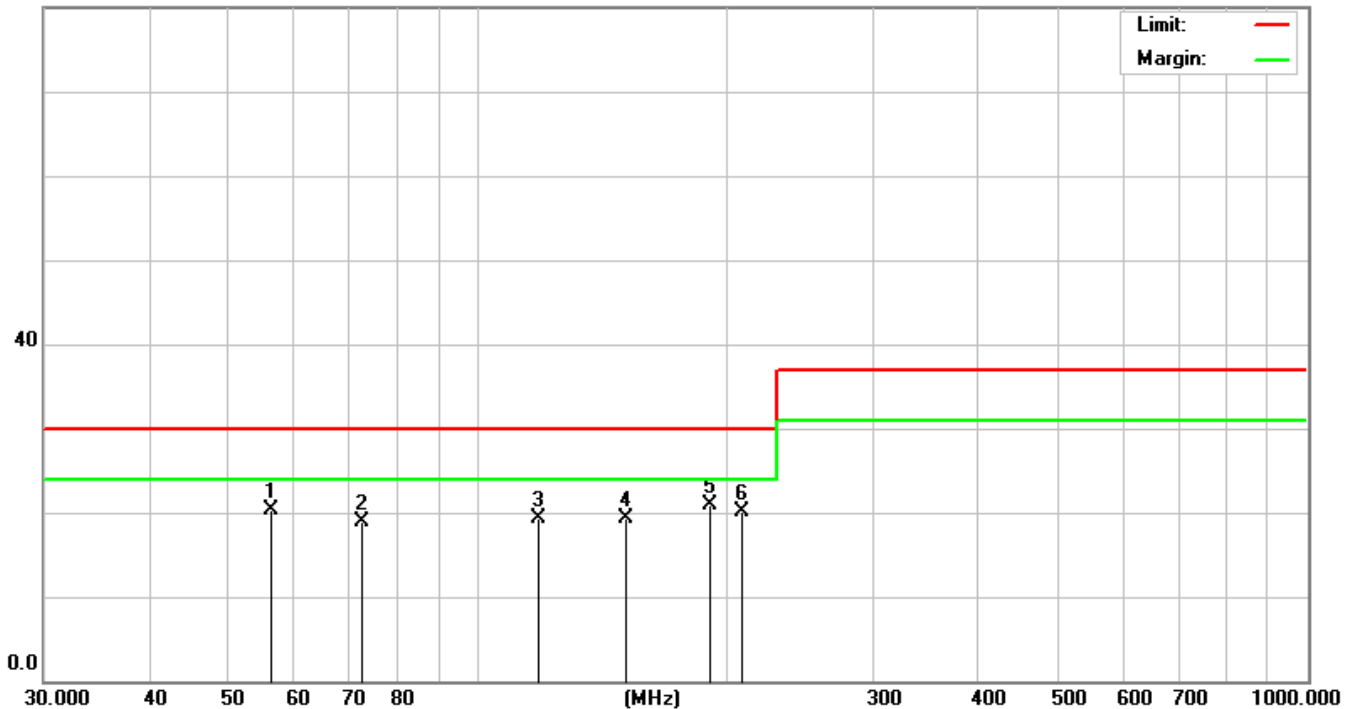

- Remark:
1. The Limit (The red line of the graph indicates the quasi -peak measurements).
 2. The Margin (The green line of the graph indicates the 6dB margin).

Date of Test	August 03, 2015	Temperature	25 deg/C
EUT	AC Adapter	Humidity	60 %RH
Working Cond.	Mode 48	Display Pattern	N/A
Antenna distance	10m at Horizontal	Test Frequency Range	30-1000MHz
Test Power Supply	AC 120V/60Hz		

No.	Frequency MHz	Reading Level dBμV	Factor dB	Measurement dBμV/m	Limit dBμV/m	Over Limit dB	Detector
1	55.8200	36.62	-19.18	17.44	30.00	-12.56	QP
2	76.3200	35.25	-18.74	16.51	30.00	-13.49	QP
3	★122.0200	31.25	-13.32	17.93	30.00	-12.07	QP
4	161.9580	29.80	-14.53	15.27	30.00	-14.73	QP
5	193.6300	30.02	-14.81	15.21	30.00	-14.79	QP
6	221.2230	30.44	-13.08	17.36	30.00	-12.64	QP

Remarks:

1. All Readings below 1GHz are Quasi-Peak.
2. Measurement = Reading + Factor (Could have ±0.01 tolerance due to computer automatically round off calculation).
3. Over Limit (Margin Value)=Measurement level-Limit value.
4. Factor = antenna factor + cable loss – amplifier gain.
5. “★” means that this data is the worst case measurement level.
6. The antenna height could have ±1cm tolerance and the turn table degree could have ±1° tolerance.
7. The measurement uncertainty is 4.10 dB.

80.0 dBμV/m

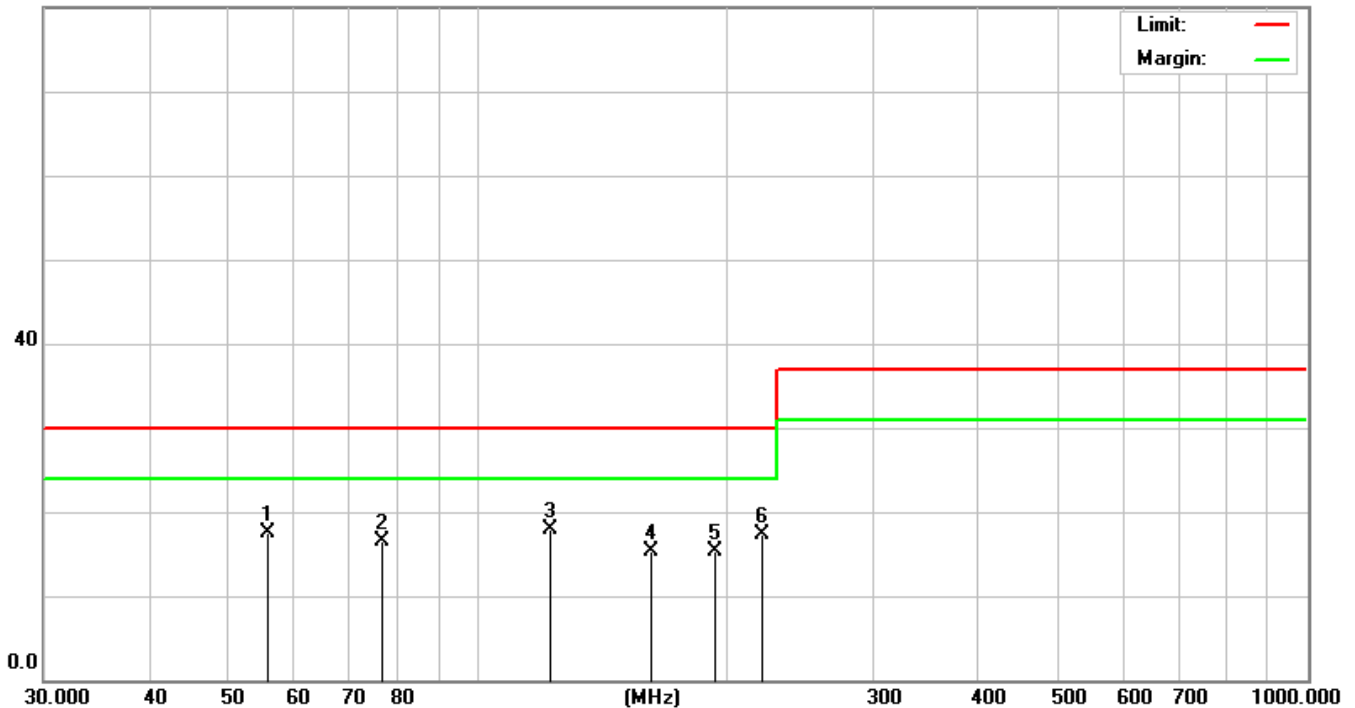

- Remark:
1. The Limit (The red line of the graph indicates the quasi -peak measurements).
 2. The Margin (The green line of the graph indicates the 6dB margin).

Date of Test	August 03, 2015	Temperature	25 deg/C
EUT	AC Adapter	Humidity	60 %RH
Working Cond.	Mode 48	Display Pattern	N/A
Antenna distance	10m at Vertical	Test Frequency Range	30-1000MHz
Test Power Supply	AC 120V/60Hz		

No.	Frequency MHz	Reading Level dBμV	Factor dB	Measurement dBμV/m	Limit dBμV/m	Over Limit dB	Detector
1	★55.8500	40.23	-19.18	21.05	30.00	-8.95	QP
2	75.9500	38.66	-18.77	19.89	30.00	-10.11	QP
3	121.1100	33.00	-13.30	19.70	30.00	-10.30	QP
4	150.6390	34.26	-14.09	20.17	30.00	-9.83	QP
5	190.6250	35.91	-14.88	21.03	30.00	-8.97	QP
6	208.2200	33.02	-14.05	18.97	30.00	-11.03	QP

Remarks:

1. All Readings below 1GHz are Quasi-Peak.
2. Measurement = Reading + Factor (Could have ±0.01 tolerance due to computer automatically round off calculation).
3. Over Limit (Margin Value)=Measurement level-Limit value.
4. Factor = antenna factor + cable loss – amplifier gain.
5. “★” means that this data is the worst case measurement level.
6. The antenna height could have ±1cm tolerance and the turn table degree could have ±1° tolerance.
7. The measurement uncertainty is 4.10 dB.

80.0 dBμV/m

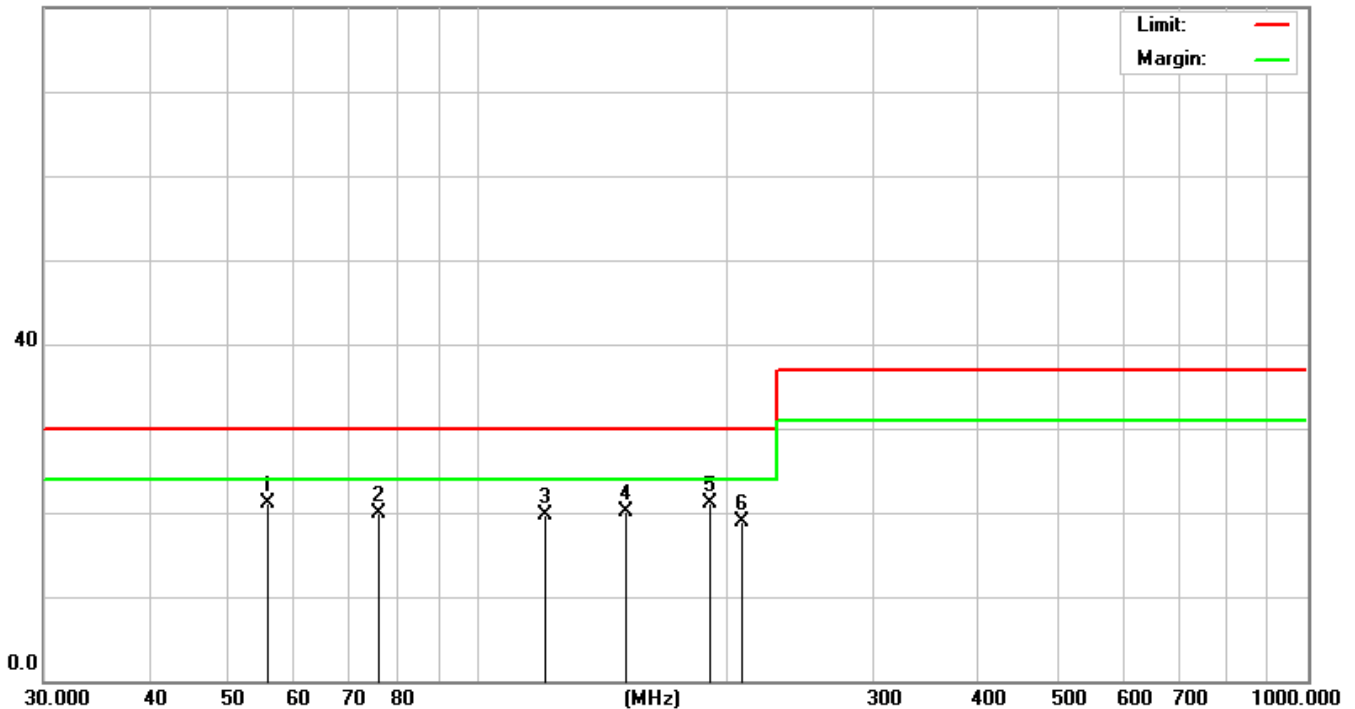

- Remark:
1. The Limit (The red line of the graph indicates the quasi -peak measurements).
 2. The Margin (The green line of the graph indicates the 6dB margin).

6. PHOTOGRAPHS FOR TEST

6.1 TEST PHOTOGRAPHS FOR CONDUCTION

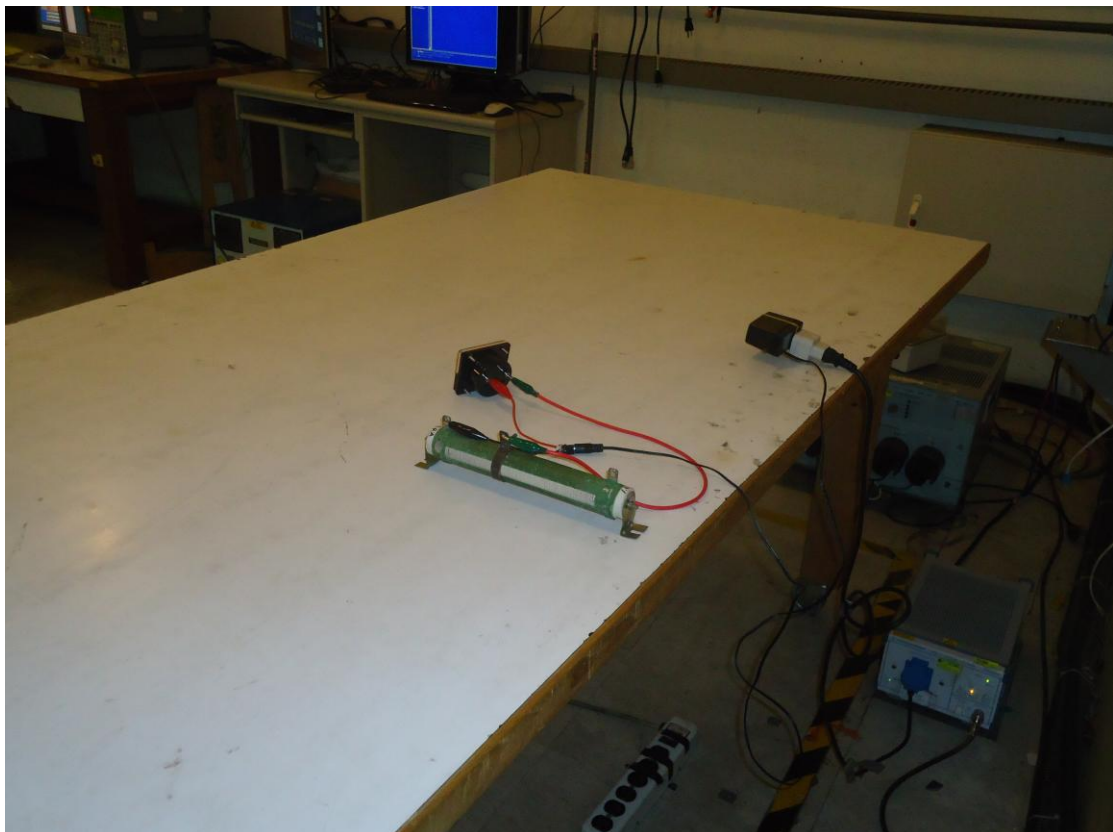

6.2 TEST PHOTOGRAPHS FOR RADIATED (30 MHz to 1 GHz)

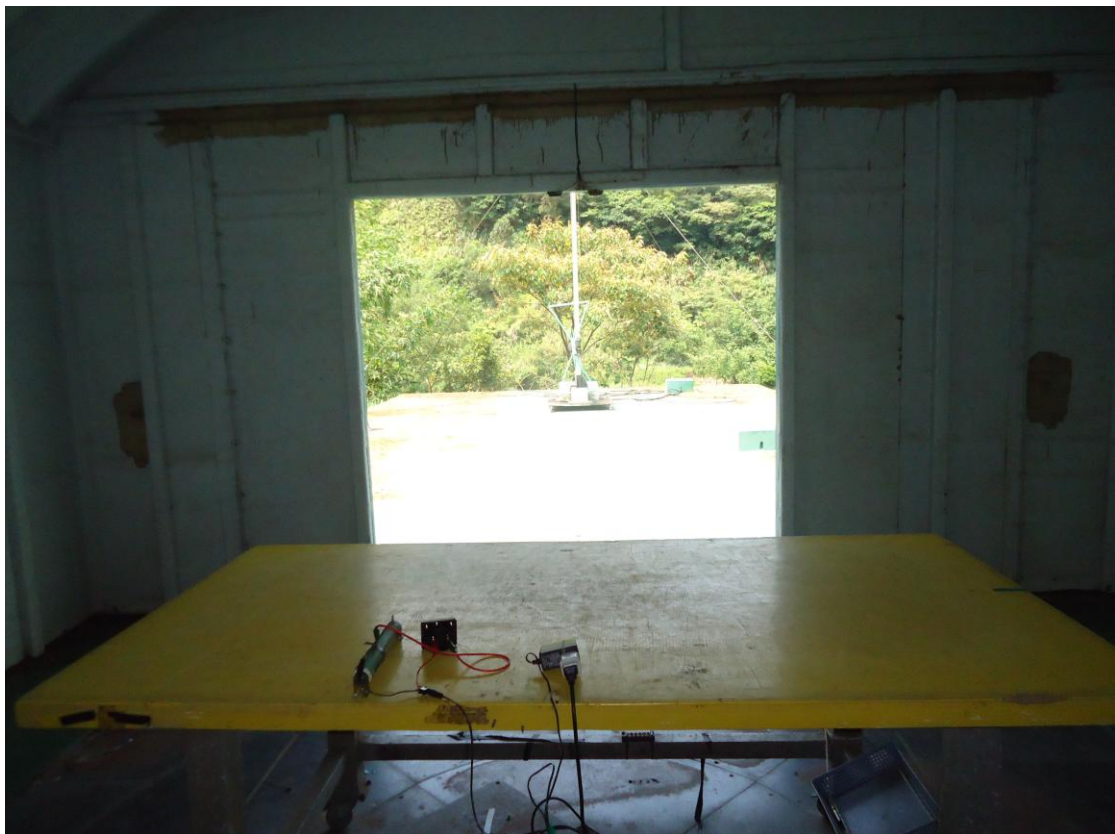

7. PHOTOGRAPHS FOR PRODUCT

1. Front View of AC Adapter. (Desk Top type)
2. Back View of AC Adapter. (Desk Top type)



7. Component Side of Mother Board. (SR)

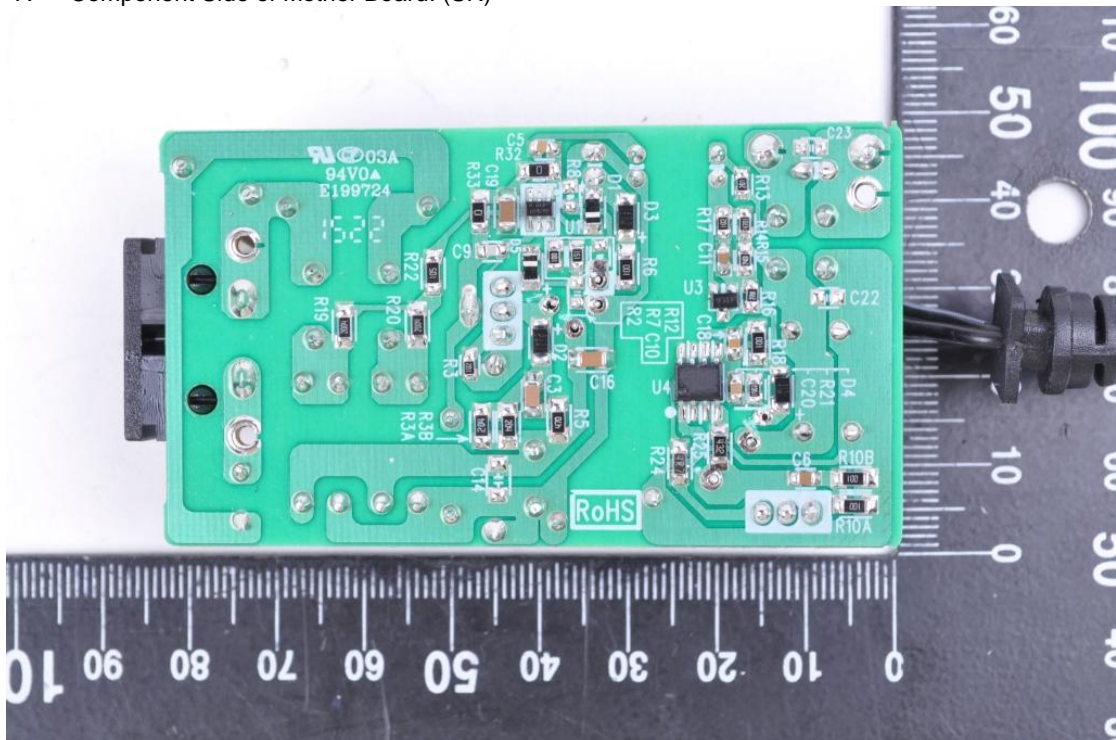

- 8. Component Side of Mother Board. (SBD)
- 9. Component Side of Mother Board. (SBD)

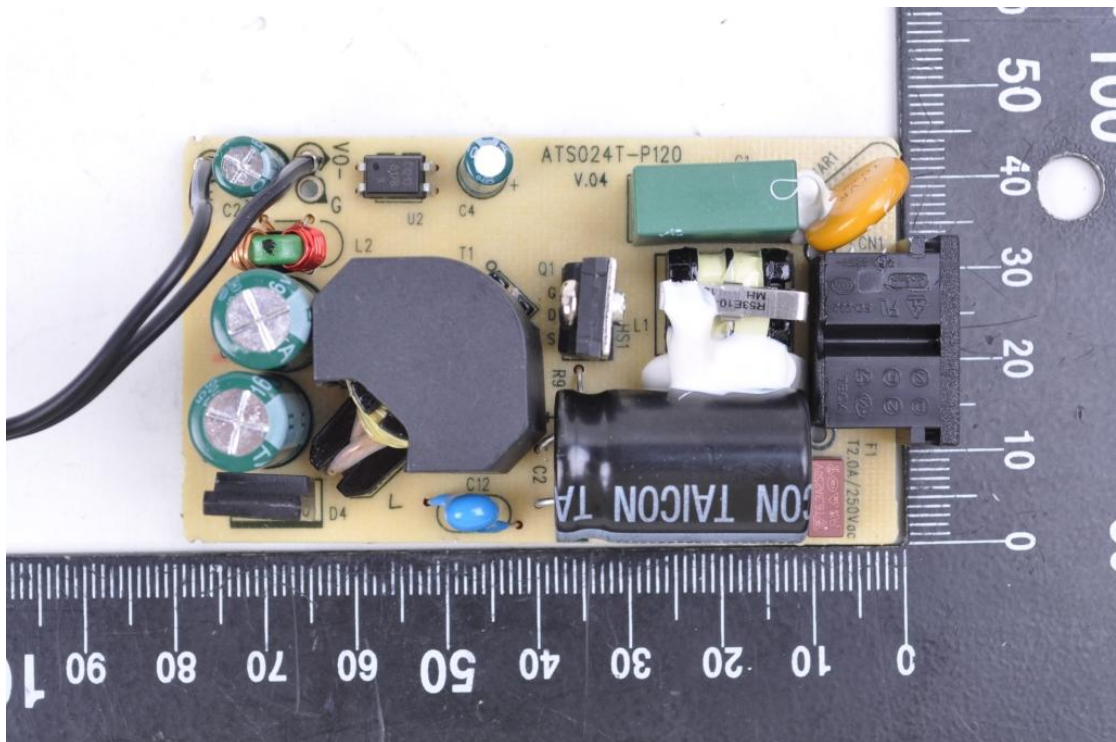
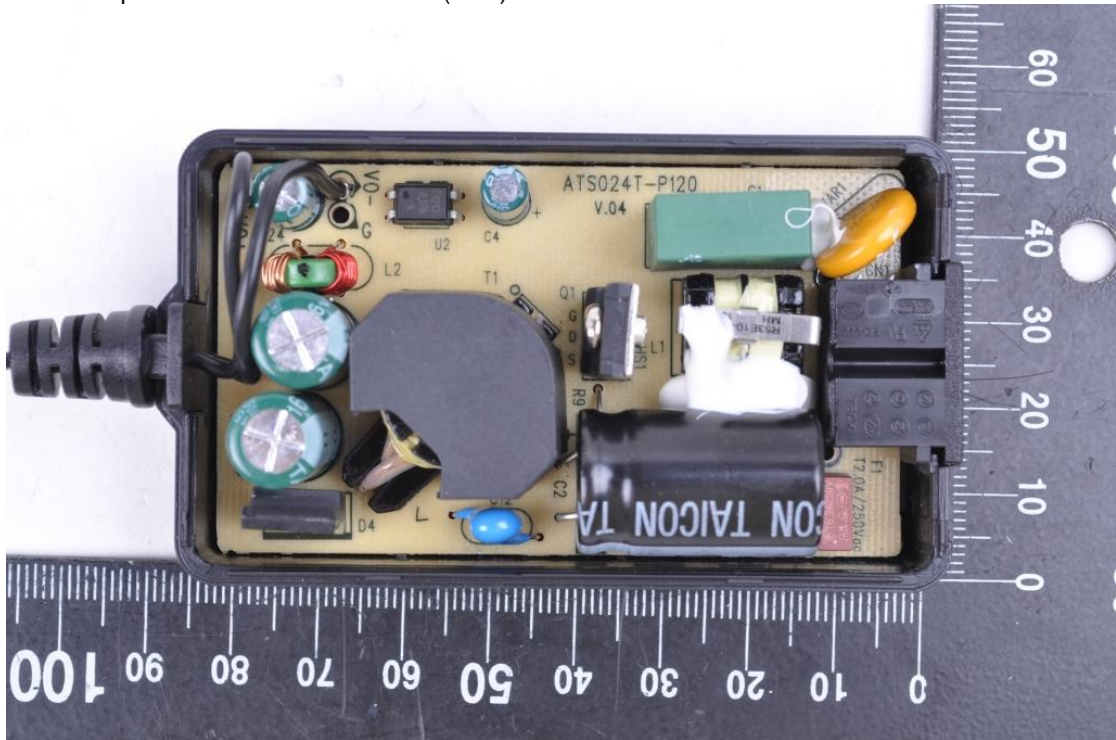

- 10. Component Side of Mother Board. (SBD)
- 11. Component Side of Mother Board. (SBD)

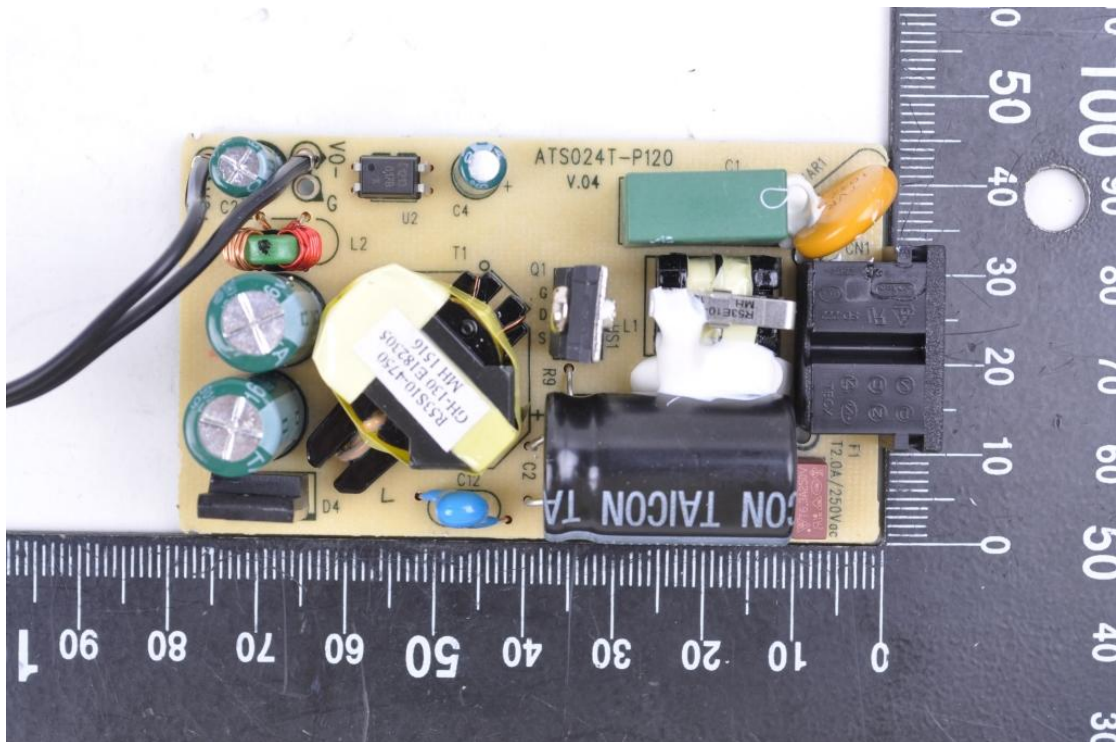
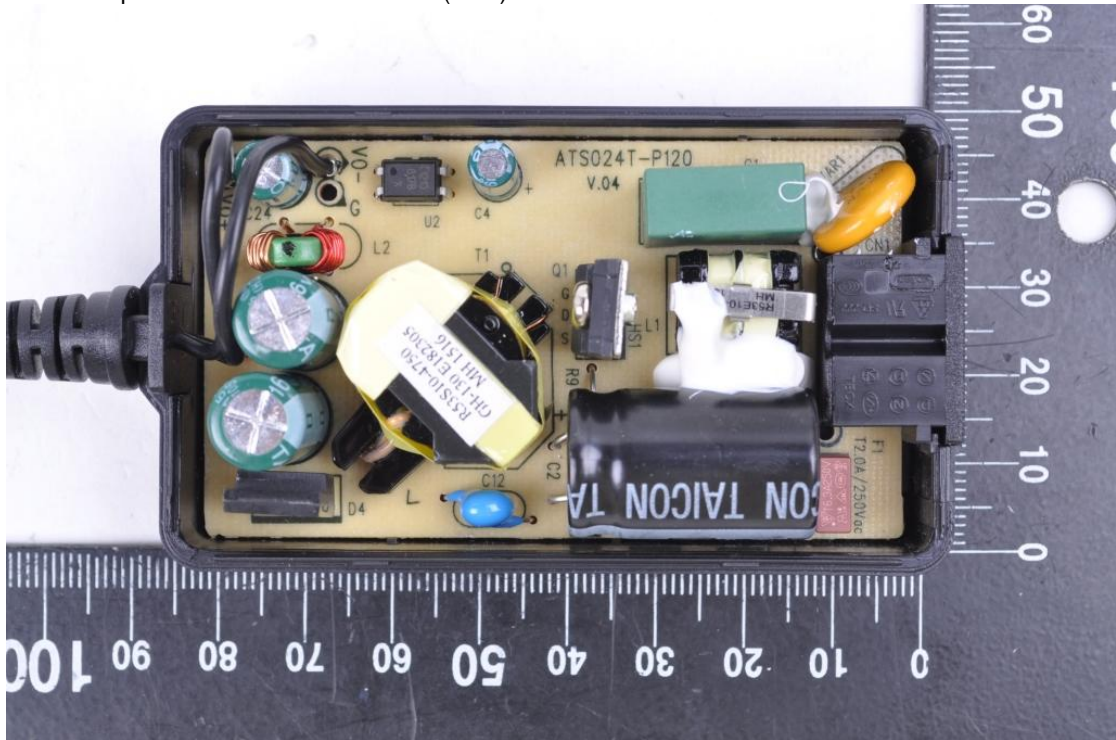

12. Solder Side of Mother Board. (SBD)

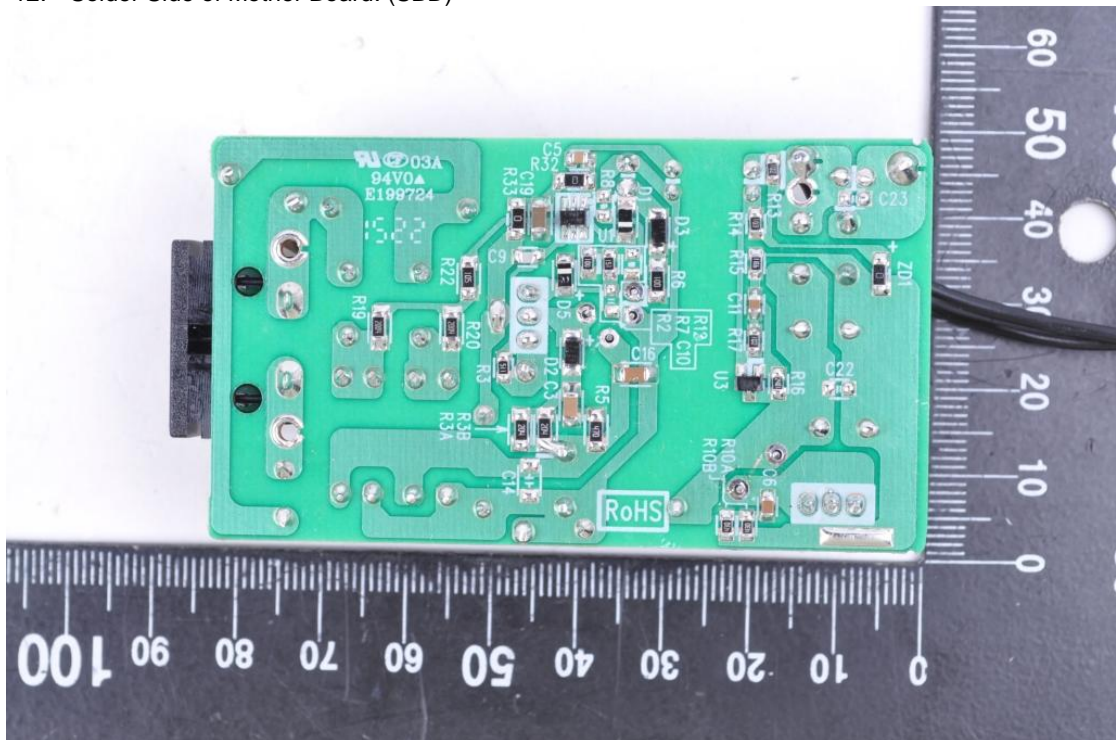

13. Front View of AC Adapter. (Direct Plug In type)
14. Back View of AC Adapter. (Direct Plug In type)



- 15. Inner.
- 16. Inner.

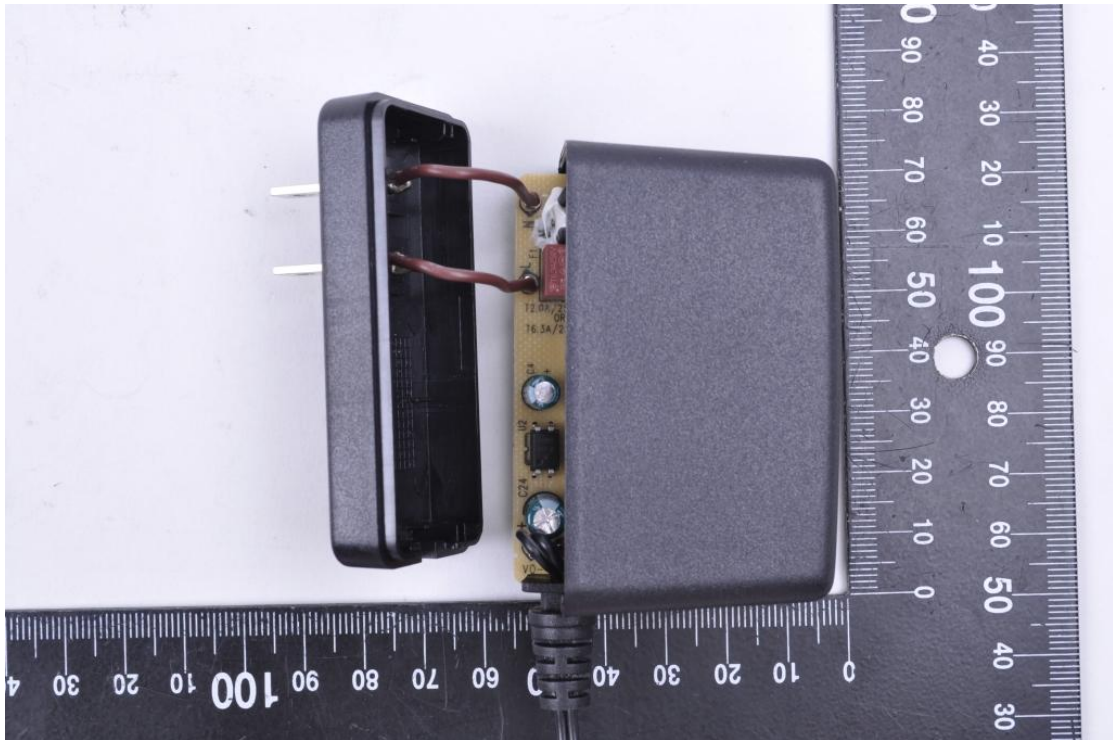

- 17. Inner.
- 18. Component Side of Mother Board.(SR)

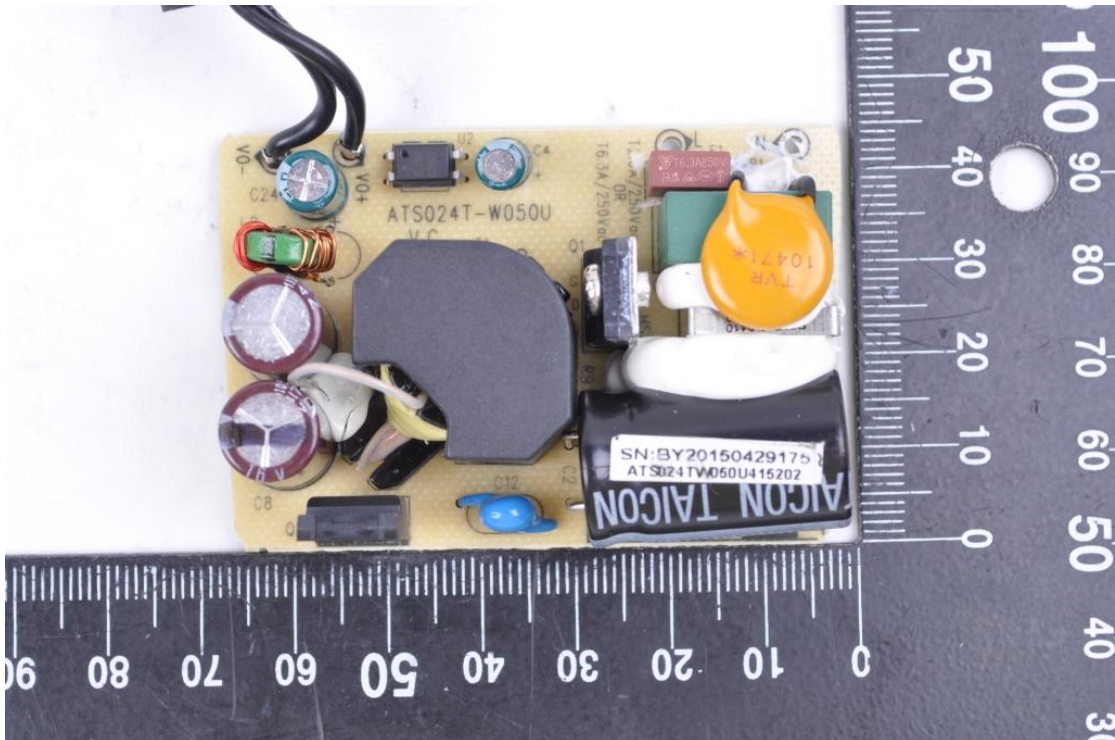

- 19. Inner.
- 20. Component Side of Mother Board.(SR)

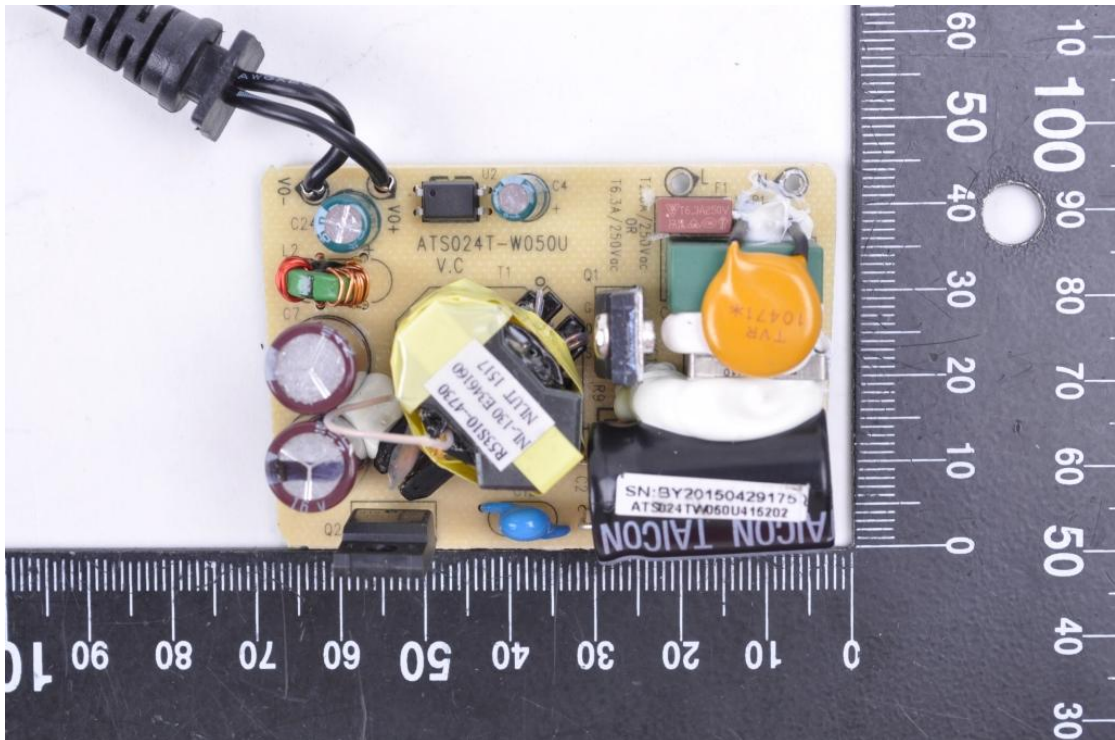
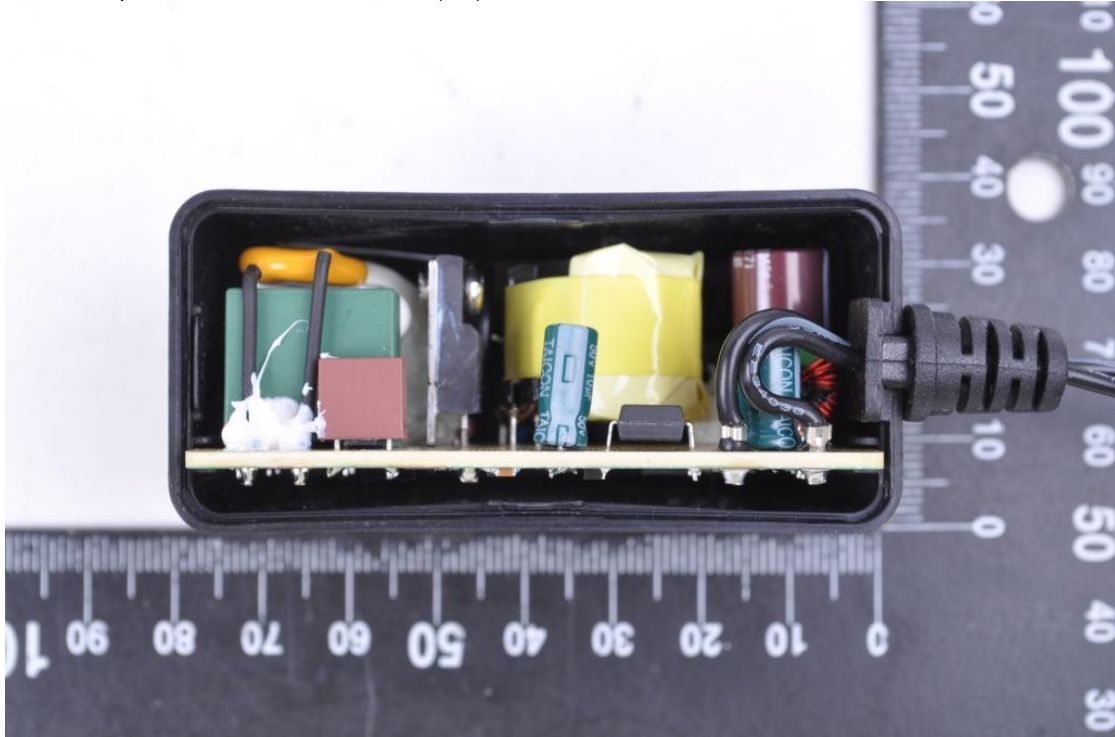

- 21. Solder Side of Mother Board. (SR)
- 22. Component Side of Mother Board.(SBD)

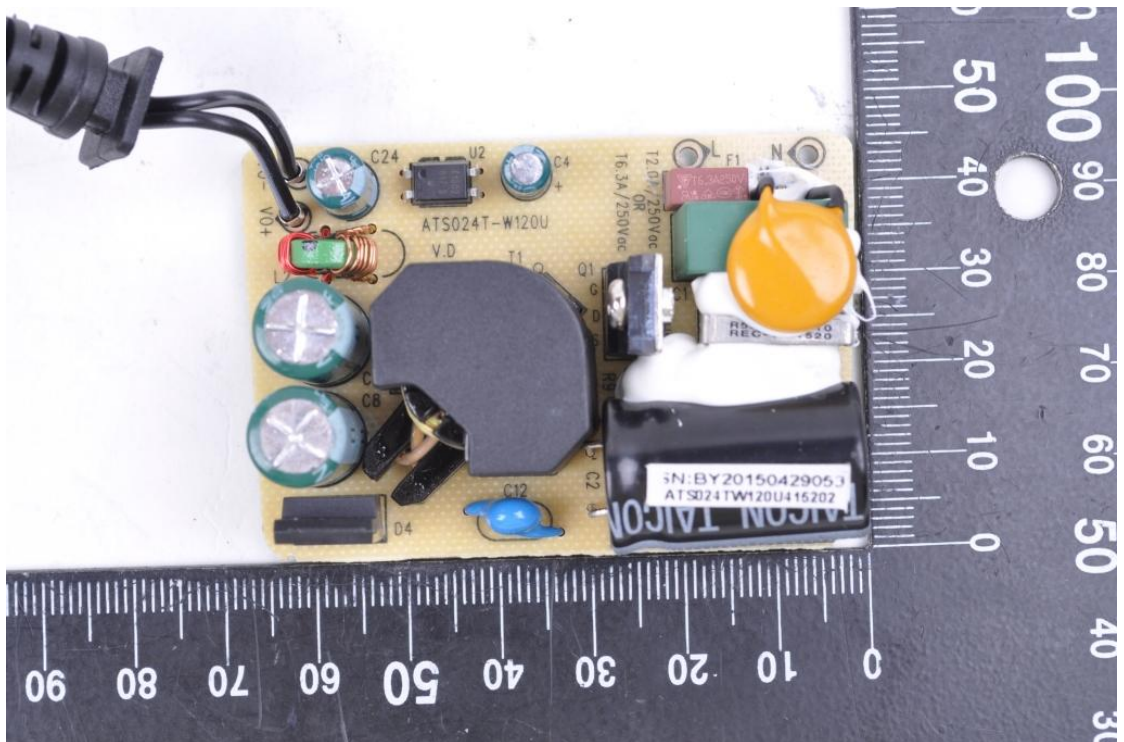
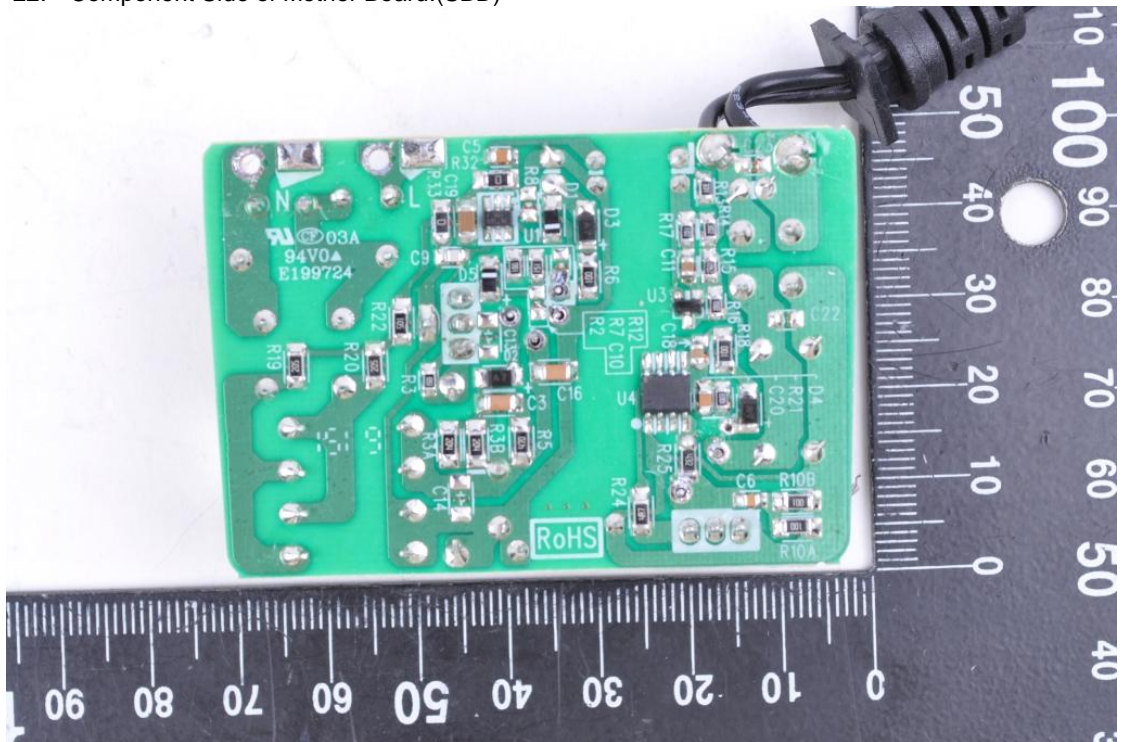

- 23. Component Side of Mother Board.(SBD)
- 24. Solder Side of Mother Board. (SBD)

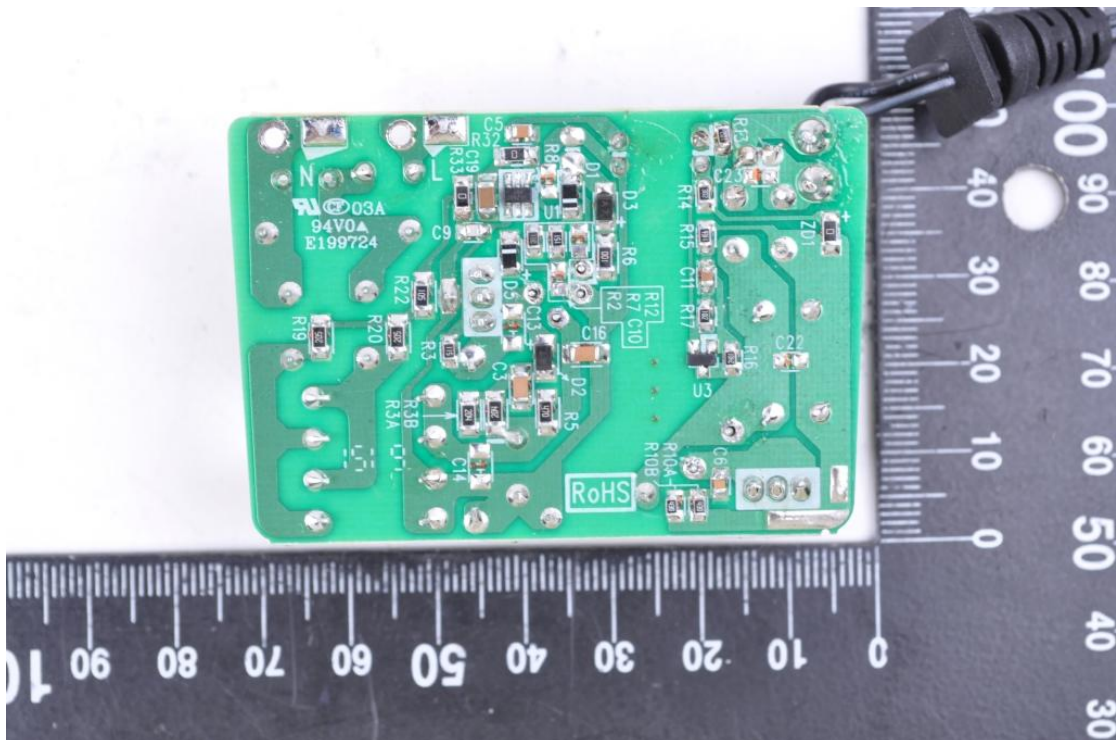
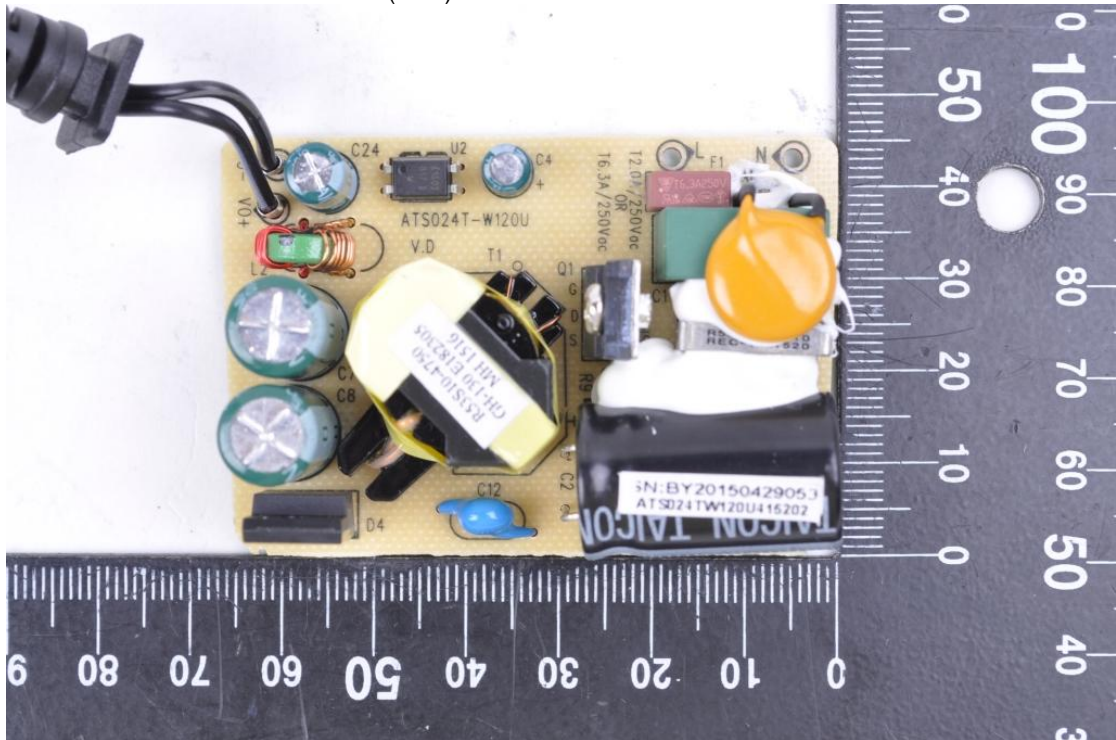

- 25. Front View of AC Adapter. (US plug)
- 26. Back View of AC Adapter. (US plug)

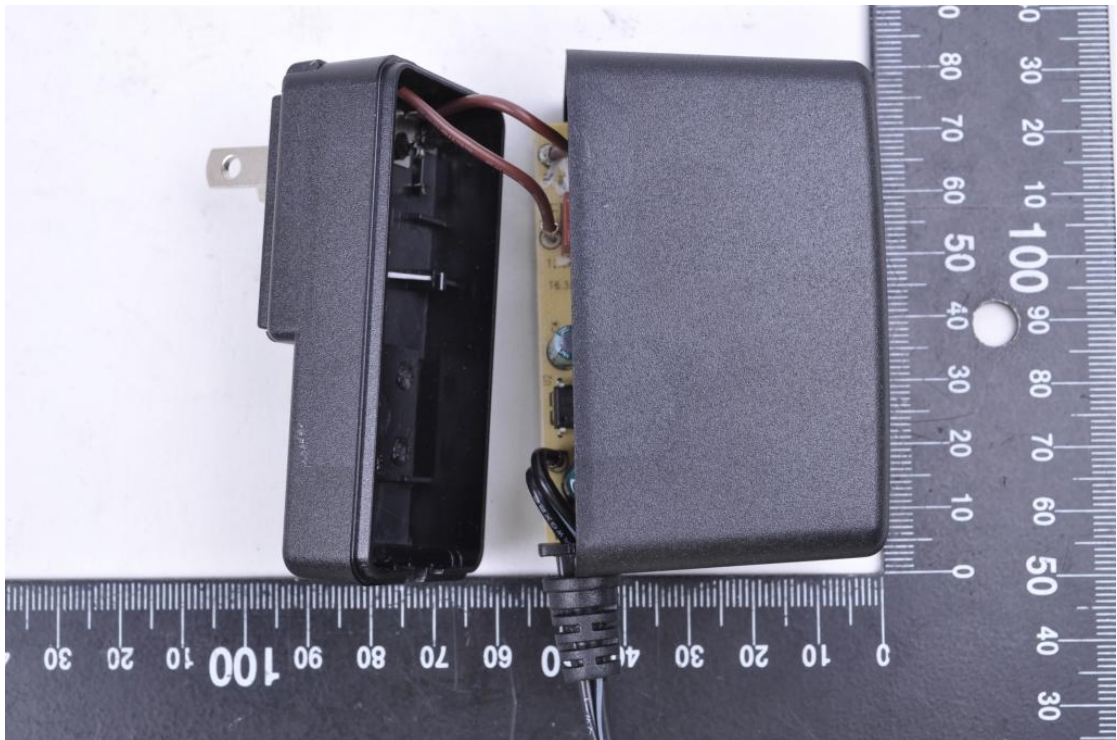
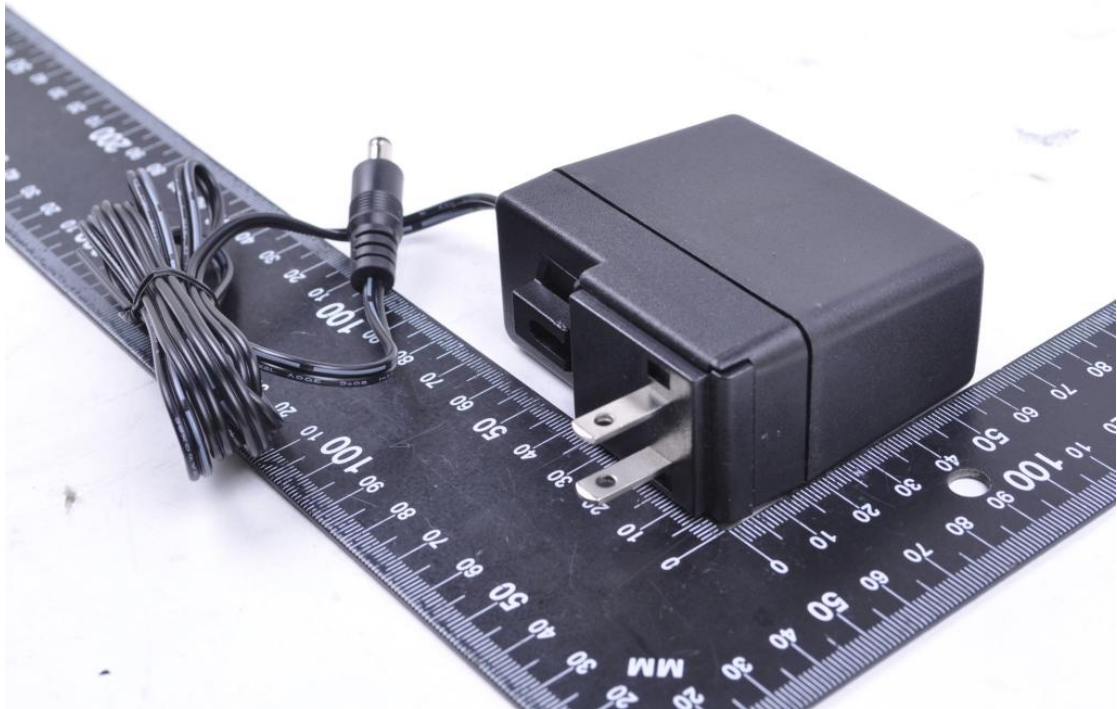

8. EMI/EMS REDUCTION METHOD DURING COMPLIANCE TESTING

No modification was made during testing.

Appendix A

Circuit (Block) Diagram

(Shall be added by Applicant)

Appendix B

User Manual

(Shall be added by Applicant)